

P-10374-1

X1414

26936

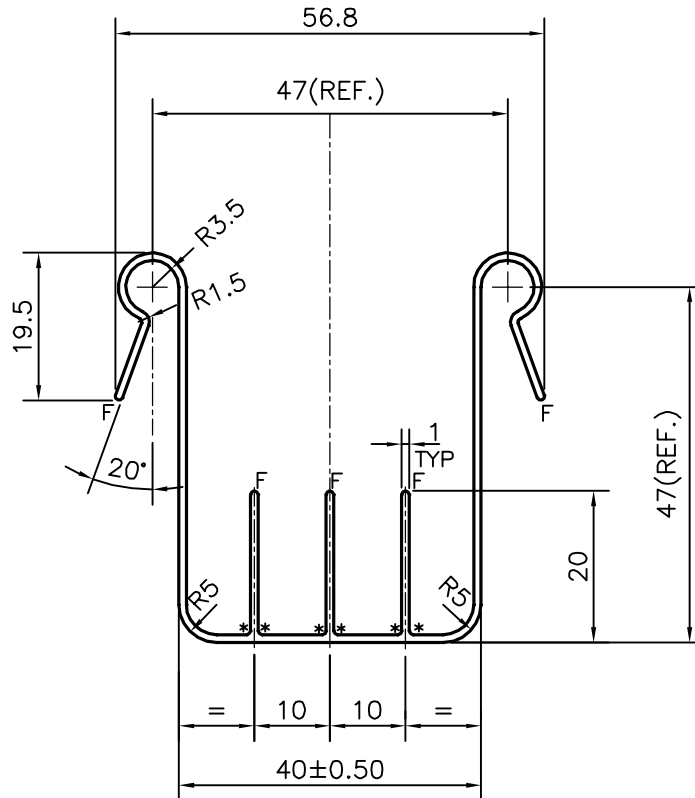

F= FULL RADIUS (5 PLACES)

*= 0.5 RADIUS (6 PLACES)



SYMBOL OF QUALITY
AN ISO 9001 COMPANY

JINDAL ALUMINIUM LTD.
BANGALORE-560073 (INDIA)

	NAME	DATE
DRAWN	J.P.KAUSHIK	24-09-2010
CHECKED		
APPROVED	S.S.GARG	30-10-2010
SCALE		1:1
AREA mm ²		243.887
PERIMETER mm.		486.77
WEIGHT kg/m		0.658
DRAWING No.	SECTION No.	
P-10374-1	-	
X1414	X1414	
26936	26936	

1. ALL DIMENSIONS ARE IN mm.
2. ROUND OFF ALL SHARP CORNERS WITH 0.40 mm.
3. TOLERANCES WILL BE AS PER IS:3965-1981 UNLESS OTHERWISE SPECIFIED

PARTY'S NAME	WESTERN REERIGERATION PVT. LTD., SHAHAPUR
PARTY'S DRAWING No.	0302008_A
ALLOY & TEMPER	6063 T6
DESCRIPTION	HEAT EXCHANGER