

P-16147-1

26964

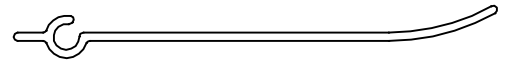

SCALE:1.1

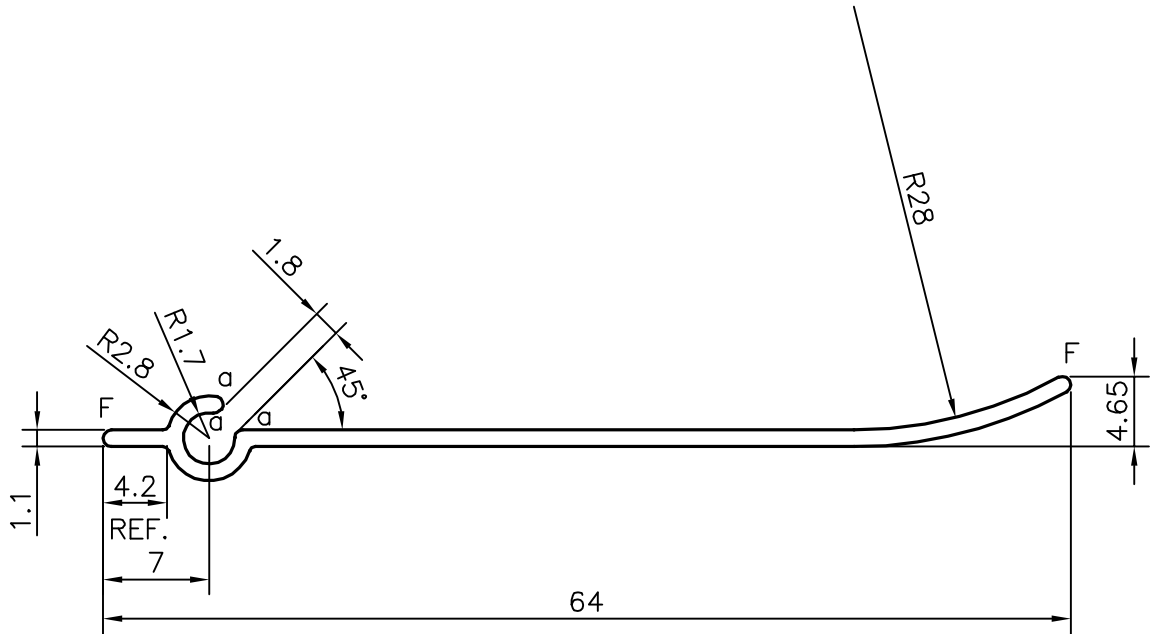

F=FULL RADIUS (2 PLACES)

a= RADIUS 0.50 (3 PLACES)



SYMBOL OF QUALITY
AN ISO 9001 COMPANY

JINDAL ALUMINIUM LTD.
BANGALORE-560073 (INDIA)

	NAME	DATE
DRAWN	KIRAN	10-08-2016
CHECKED		
APPROVED	S.S. GARG	23-09-2016
SCALE		2:1
AREA mm ²		77.839
PERIMETER mm.		142.627
WEIGHT kg/m		0.210
DRAWING No.	SECTION No.	
P-16147-1	-	
26964	26964	

1. ALL DIMENSIONS ARE IN mm.
2. ROUND OFF ALL SHARP CORNERS WITH 0.40 mm.
3. TOLERANCES WILL BE AS PER EN:755/9 , UNLESS OTHERWISE SPECIFIED

PARTY'S NAME	DASCO, KUWAIT
PARTY'S DRAWING No.	AS PER DRAWING
ALLOY & TEMPER	6063 T6
DESCRIPTION	AIR GRILL SECTION