

P-13968

S4228

26969

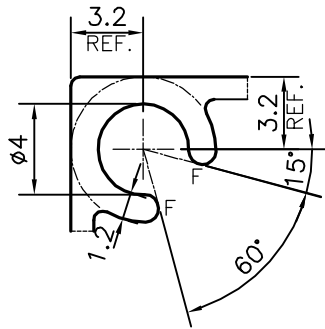

DETAIL OF "A"  
SCALE 3:1

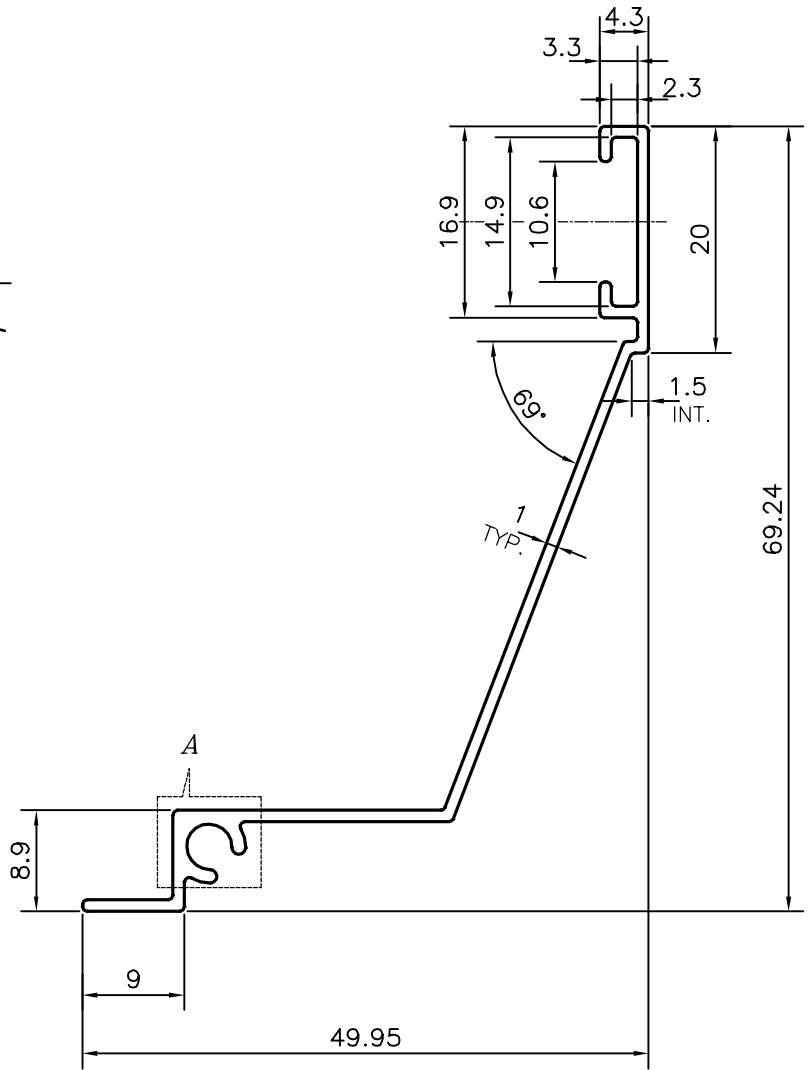

F = FULL RADIUS (2 PLACES)

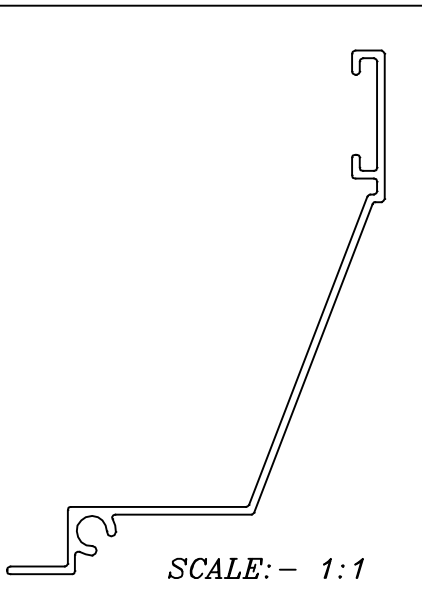

TOLERANCES ON OVERALL WIDTHS & WIDTHS ACROSS FLATS OF BARS, & REGULAR SECTIONS

UPTO 6.40mm - ±0.20	UPTO 32.0mm - ±0.38	UPTO 120.0mm - ±0.85	1. STRAIGHTNESS=1.7mm/M 2. TWIST=1.7mm/M 3. ANGULARITY= ±2° 4. FLATNESS =0.007xWIDTH
UPTO 10.0mm - ±0.23	UPTO 50.0mm - ±0.46	UPTO 160.0mm - ±1.02	
UPTO 12.0mm - ±0.25	UPTO 60.0mm - ±0.53	UPTO 200.0mm - ±1.14	
UPTO 16.0mm - ±0.28	UPTO 80.0mm - ±0.69	UPTO 250.0mm - ±1.40	
UPTO 25.0mm - ±0.30	UPTO 100.0mm - ±0.75	UPTO 300.0mm - ±1.65	



SYMBOL OF QUALITY  
AN ISO 9001 COMPANY

**JINDAL ALUMINIUM LTD.**  
BANGALORE-560073 (INDIA)

	NAME	DATE
DRAWN	PARVESH	05-09-2014
CHECKED		
APPROVED	S.S.GARG	08-09-2014

1. ALL DIMENSIONS ARE IN mm.
2. ROUND OFF ALL SHARP CORNERS WITH 0.40 mm.
3. TOLERANCES WILL BE AS PER IS:3965-1981, UNLESS OTHERWISE SPECIFIED

SCALE	1.5:1
AREA mm <sup>2</sup>	125.85
PERIMETER mm.	238.677
WEIGHT kg/m	0.34

PARTY'S NAME	JAYDEE UTILITY CONSULTANTS PVT. LTD., BANGALORE
PARTY'S DRAWING No.	MODIFIED OF SECTION NO. 26601
ALLOY & TEMPER	HE9 WP
DESCRIPTION	AIR GRILL SECTION

DRAWING No.	SECTION No.
P-13968	P-13968
S4228	S4228
26969	26969