

P-16766

26974

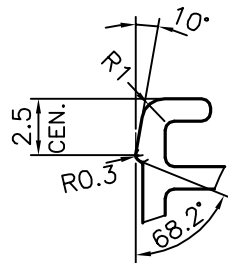

DETAIL OF "A"
SCALE 3:1

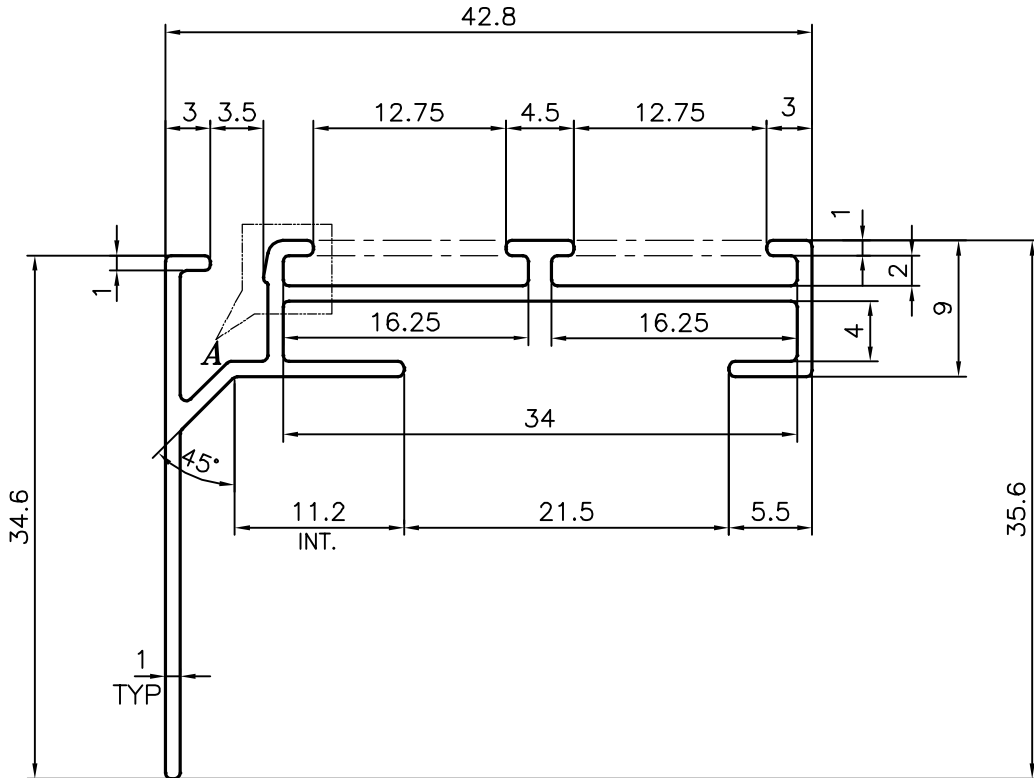
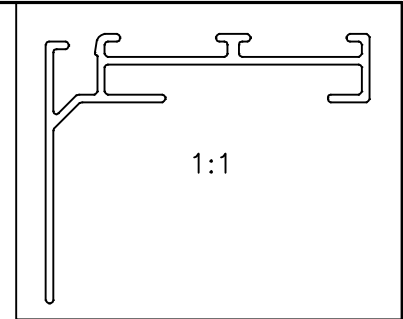

TOLERANCE CHART CD = CIRCUMSCRIBING CIRCLE

	CD ≤ 100	100 < CD ≤ 200	200 < CD < 300	300 < CD < 500
UPTO 10mm -	±0.25	±0.30	±0.35	±0.40
10.0 - 25.0 -	±0.30	±0.40	±0.50	±0.60
25.0 - 50.0 -	±0.50	±0.60	±0.80	±0.90
50.0 - 100.0 -	±0.70	±0.90	±1.10	±1.30
100 - 150 -	-	±1.10	±1.30	±1.50
150 - 200 -	-	±1.3	±1.50	±1.80
200 - 300 -	-	-	±1.70	±2.10
300 - 450 -	-	-	-	±2.80



SYMBOL OF QUALITY
AN ISO 9002 COMPANY

JINDAL ALUMINIUM LTD.
BANGALORE-560073 (INDIA)

	NAME	DATE
DRAWN	J.P.KAUSHIK	21-01-2017
CHECKED		
APPROVED	B.NATARAJ	15-03-2017
SCALE		2:1
AREA mm ²		119.979
PERIMETER mm.		231.243
WEIGHT kg/m		0.324
DRAWING No.	SECTION No.	
P-16766	-	
26974	26974	

- ALL DIMENSIONS ARE IN mm.
- ROUND OFF ALL SHARP CORNERS WITH 0.40 mm.
- TOLERANCES WILL BE AS PER BS:EN-755-9, UNLESS OTHERWISE SPECIFIED

PARTY'S NAME	KBE INTERNATIONAL SAL, LEBANON MIDDLE EAST
PARTY'S DRAWING No.	AS PER AutoCAD DRAWING-AP-133 (1464)
ALLOY & TEMPER	6063 T6
DESCRIPTION	AIR GRILL SECTION