

P-0468

2731

27011 ISSUE-3

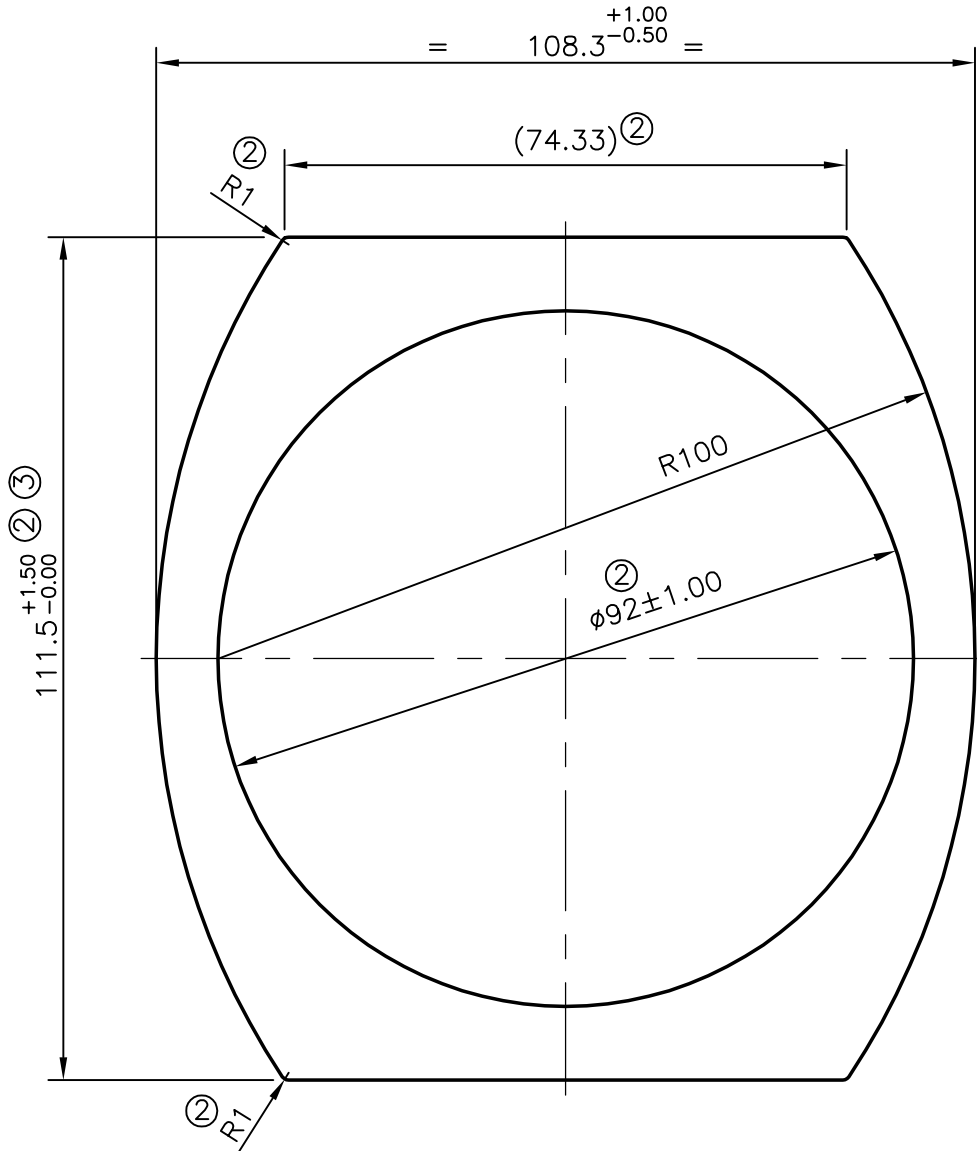

NOTE: -

DIMENSION CHANGED FROM $110 \text{ mm}^{-0.00}$ TO $111.5 \text{ mm}^{-0.50}$, 75.33 mm. TO 74.33 mm. RADIUS R 1.0 ADDED & BORE CHANGED FROM $93 \pm 1.0 \text{ mm}$ TO $92 \pm 1.0 \text{ mm}$,

WEIGHT ALSO CHANGED FROM 10.676 kg/m TO 11.371 kg/m

(3) TOLERANCE CHANGED FROM $111.5 \text{ mm}^{-0.50}$ TO $111.5 \text{ mm}^{-0.00}$

 SYMBOL OF QUALITY AN ISO 9002 COMPANY	JINDAL ALUMINIUM LTD. BANGALORE-560073 (INDIA)	NAME		DATE	
		DRAWN	ABHARANI	20-08-2008	
		CHECKED			
1. ALL DIMENSIONS ARE IN mm. 2. ROUND OFF ALL SHARP CORNERS WITH 0.40 mm. 3. TOLERANCES WILL BE AS PER IS:6477-1983 UNLESS OTHERWISE SPECIFIED		SCALE		1:1	
		AREA mm ²	4211.564		
PARTY'S NAME		M/S PRIMA CONTROLS (P) LTD, POONA		PERIMETER mm.	384.87
		PARTY'S DRAWING No.		P.R.C-0005/1/EXT.	WEIGHT kg/m
ALLOY & TEMPER		HE30 WP		DRAWING No.	SECTION No.
		DESCRIPTION		ACTUATOR BODY	P-0468
				2731	2731
				27011	27011 ISSUE-3