

P-3727

7982

27016

1. TWIST TOLERANCE 0.25°/300mm
2. MINIMUM HARDNESS = 95 HB
3. DEFLECTION 3mm/m
4. TOLERANCES WILL BE AS PER THE DRAWING & EN 755-9 (EUROPEAN STANDARD)

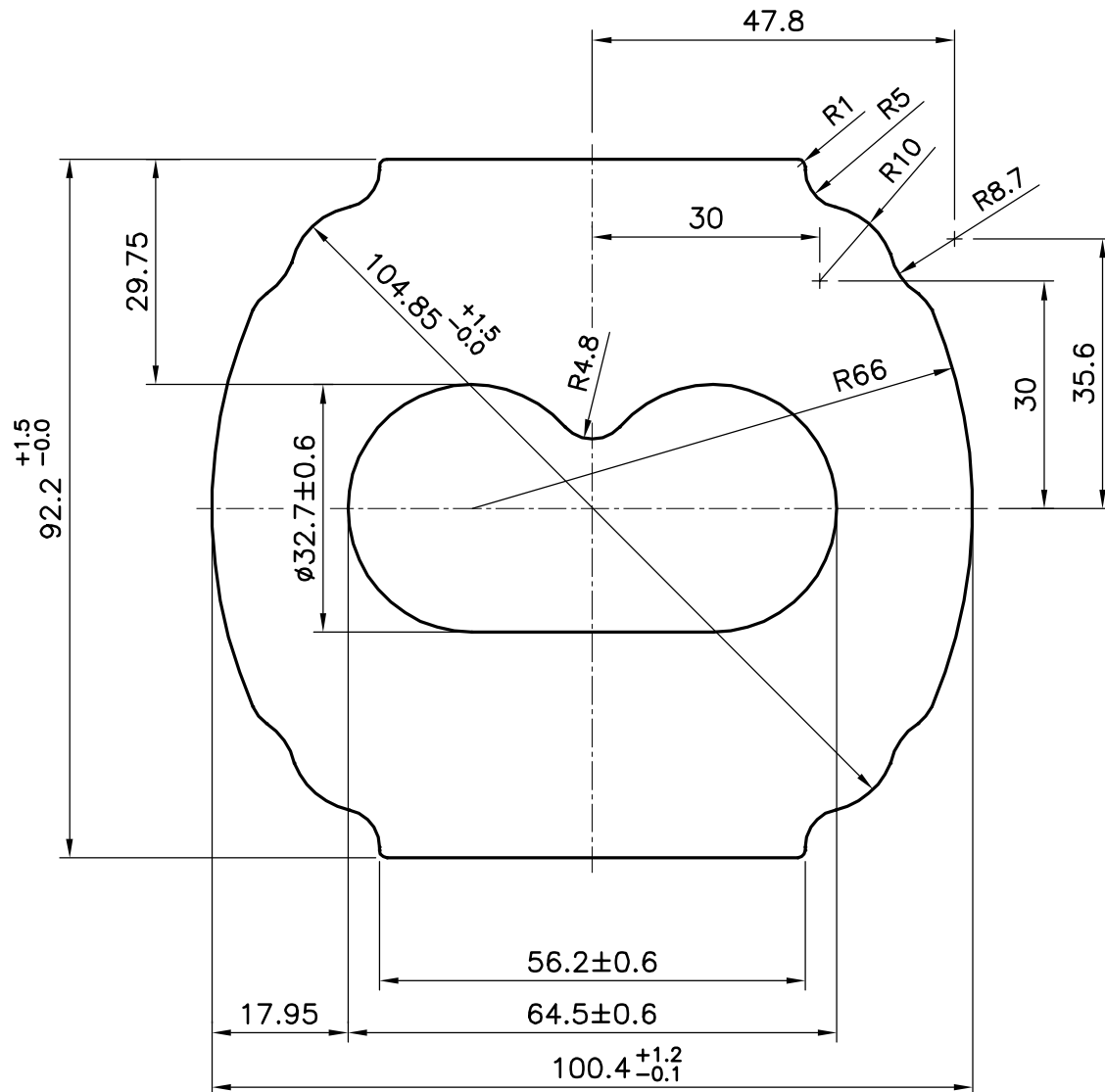

SYMBOL OF QUALITY  
AN ISO 9002 COMPANY

**JINDAL ALUMINIUM LTD.**  
BANGALORE-560073 (INDIA)

NAME

DATE

DRAWN RAGHAVENDRA 08-01-02

CHECKED

APPROVED

SCALE 1:1

AREA mm<sup>2</sup> 6161.14

PERIMETER 328.72mm

WEIGHT kg/m 16.635

SECTION No. 27016

DRAWING No. 27016

1. ALL DIMENSIONS ARE IN mm.
2. ROUND OFF ALL SHARP CORNERS WITH 0.40 mm.
3. TOLERANCES WILL BE AS PER SEE NOTE-4 UNLESS OTHERWISE SPECIFIED

PARTY'S NAME JIHOSTROJ AERO TECHNOLOGY.,CZECH REPUBLIC

PARTY'S DRAWING No. AS PER DRAWING (10084)

ALLOY &amp; TEMPER Almg1SiCu (6061-T6510)

DESCRIPTION PUMP BODY