

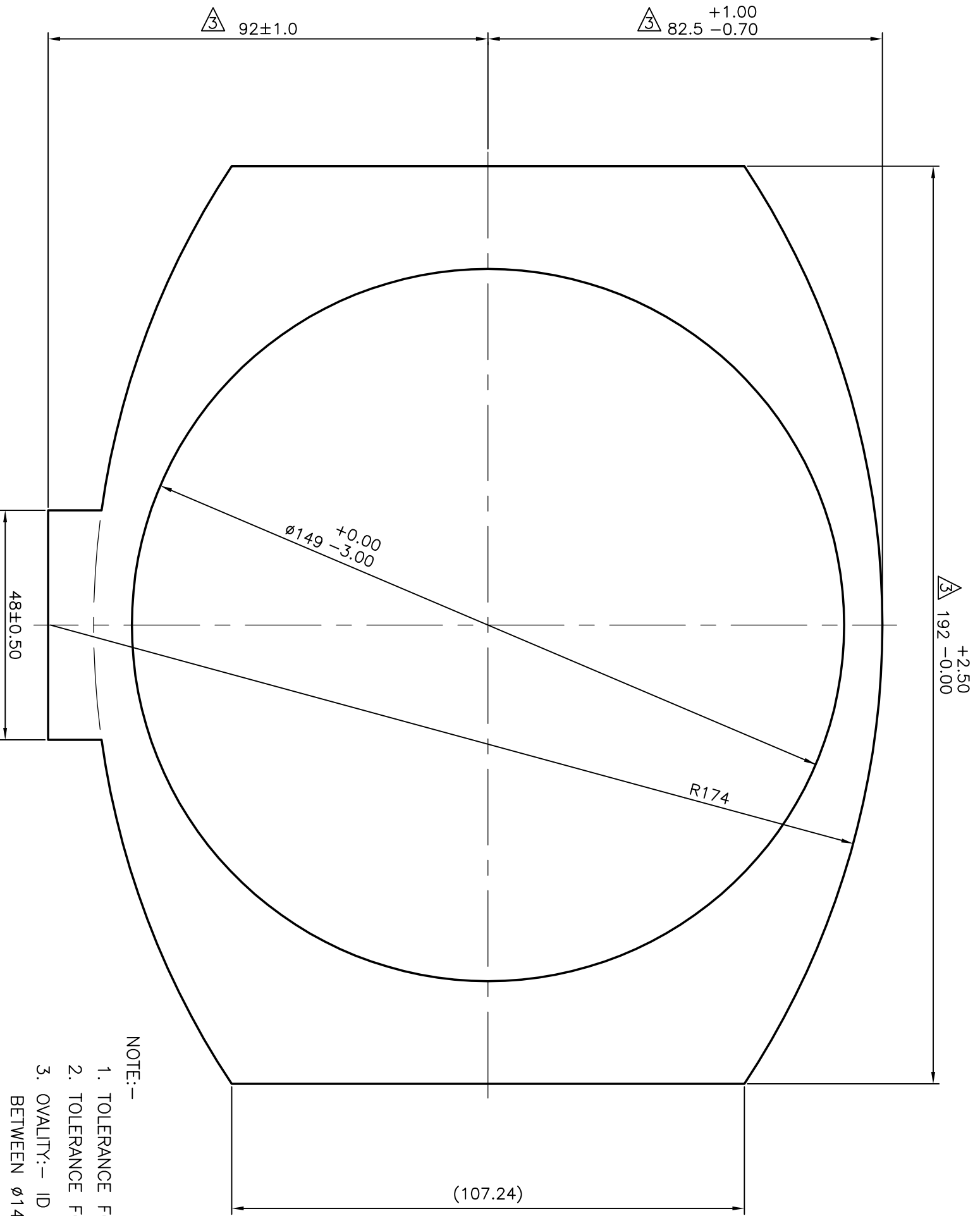

X086
7985
27018



△ DIMENSION CHANGED FROM 192±1.5 TO 192 -0.00 +2.50
 92±0.8 TO 92±1.0 +1.00
 82.5±0.7 TO 82.5 -0.70

NOTE:-
 1. TOLERANCE FOR STRAIGHTNESS = 1.7 mm/m
 2. TOLERANCE FOR TWIST = 1.7 mm/m
 3. QUALITY:- ID AT ANY POINT WILL BE BETWEEN $\phi 146$ TO $\phi 149$

 SYMBOL OF QUALITY AN ISO 9001 COMPANY		JINDAL ALUMINIUM LTD. BANGALORE-560073 (INDIA)	
1. ALL DIMENSIONS ARE IN mm. 2. ROUND OFF ALL SHARP CORNERS WITH 0.40 mm. 3. TOLERANCES WILL BE AS PER IS:6477-1983 UNLESS OTHERWISE SPECIFIED			
PARTY'S NAME	MICRO PNEUMATICS, MUMBAI	DRAWN	NAME
PARTY'S DRAWING No.	AS PER DRAWING (MP-M8155/R1)	CHECKED	DATE
ALLOY & TEMPER	HE9 WP	APPROVED	
DESCRIPTION	PUMP BODY	SCALE	1:1
		AREA mm ²	11161.507
		PERIMETER mm.	643.419
		WEIGHT kg/m	30.136
		DRAWING No.	SECTION No.
		X086	X086
		7985	7985
		27018	27018