

P-3164-3

S1356

27036

NOTE:-

1. PERMISSIBLE DEVIATION FROM STRAIGHTNESS=2mm/1000mm.
2. PERMISSIBLE DRAWING WARPAGE ALONG DIMENSION 52 = 1.5mm/1000mm
3. SAWN TAPER PER SIDE 3mm ALLOWED IN THE REGION OF LENGTH TOLERANCE

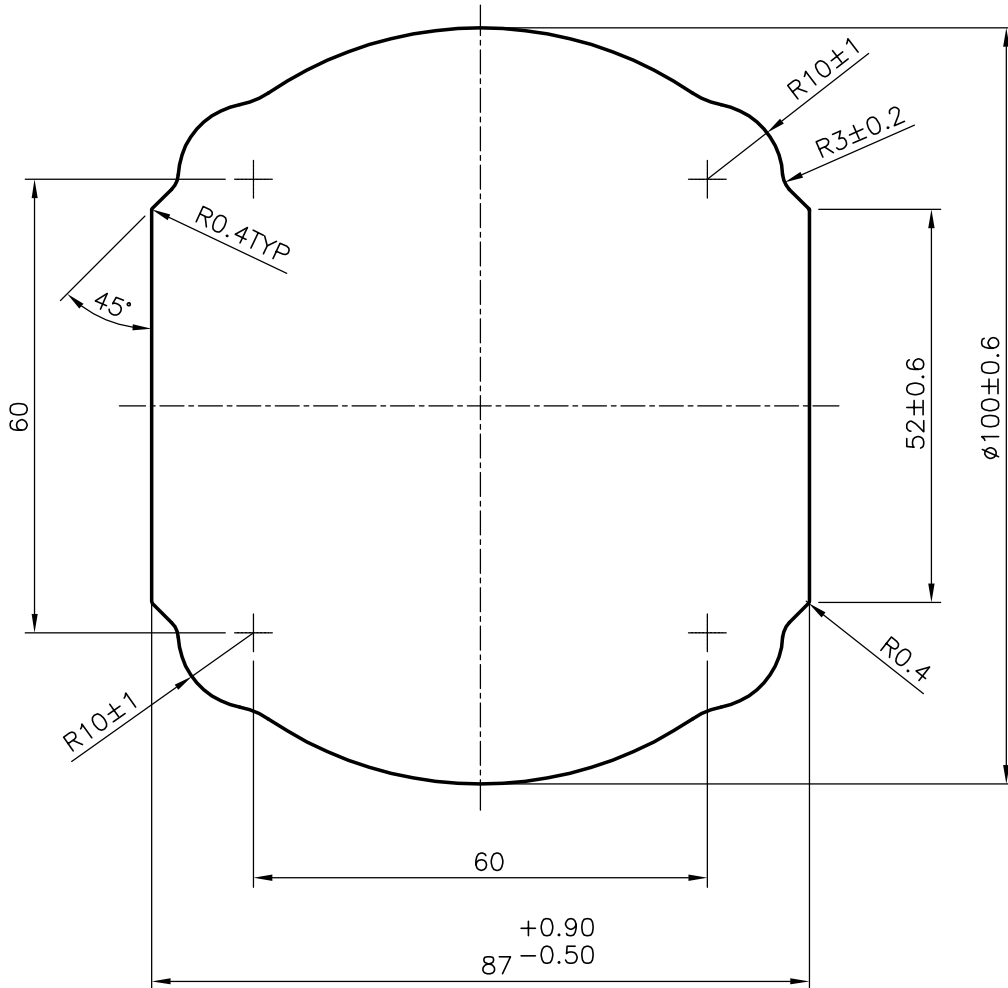

 SYMBOL OF QUALITY AN ISO 9001 COMPANY	JINDAL ALUMINIUM LTD. BANGALORE-560073 (INDIA)	NAME		DATE
		DRAWN	RAGHAVENDRA	04-10-2004
1. ALL DIMENSIONS ARE IN mm. 2. ROUND OFF ALL SHARP CORNERS WITH 0.40 mm. 3. TOLERANCES WILL BE AS PER IS:3965-1981 UNLESS OTHERWISE SPECIFIED		CHECKED		
		APPROVED		
PARTY'S NAME MIVIN ENGINEERING TECHNOLOGIES, BANGALORE		SCALE		1:1
		AREA mm ²		7522.669
PARTY'S DRAWING No. F002 E11 109		PERIMETER mm.		316.328
		WEIGHT kg/m		20.311
ALLOY & TEMPER HE30 WP		DRAWING No.		P-3164-3
		SECTION No.		-
DESCRIPTION PUMP BODY		S1356		S1356
		27036		27036