

P-4719

S1153

27041

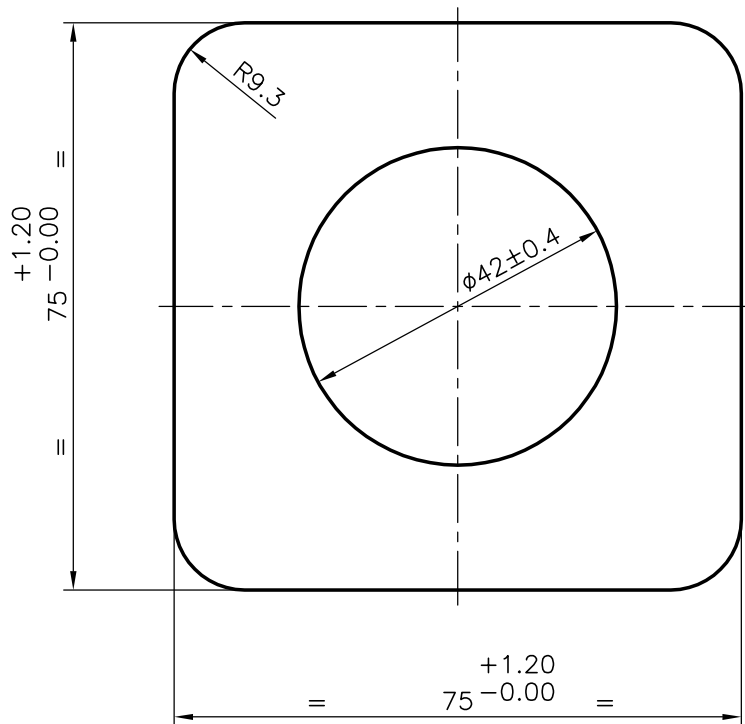

1. EXTRUSION SHOULD BE FREE FROM SCRATCHES, DENTS, CRACKS & OTHER DEFECTS
2. HARDNESS: - $85-90^2$ BHN
3. UTS = 270N/mm



SYMBOL OF QUALITY
AN ISO 9002 COMPANY

JINDAL ALUMINIUM LTD.
BANGALORE-560073 (INDIA)

| | NAME | DATE |
|----------------------|-------------|-------------|
| DRAWN | RAGHAVENDRA | 06-02-2004 |
| CHECKED | | |
| APPROVED | | |
| SCALE | | 1:1 |
| AREA mm ² | | 4165.314 |
| PERIMETER mm. | | 284.034 |
| WEIGHT kg/m | | 11.246 |
| DRAWING No. | | SECTION No. |
| P-4719 | | - |
| S1153 | | S1153 |
| 27041 | | 27041 |
| | | |
| | | |

1. ALL DIMENSIONS ARE IN mm.
2. ROUND OFF ALL SHARP CORNERS WITH 0.40 mm.
3. TOLERANCES WILL BE AS PER IS:6477-1983 UNLESS OTHERWISE SPECIFIED

| | |
|---------------------|------------------------------------|
| PARTY'S NAME | VELJAN HYDRAIR PVT. LTD. HYDERABAD |
| PARTY'S DRAWING No. | V3013180-4 A |
| ALLOY & TEMPER | 64430 WP (AS PER IS:733-1983) |
| DESCRIPTION | MISC HOLLOW |