

P-6285

S1731

27046

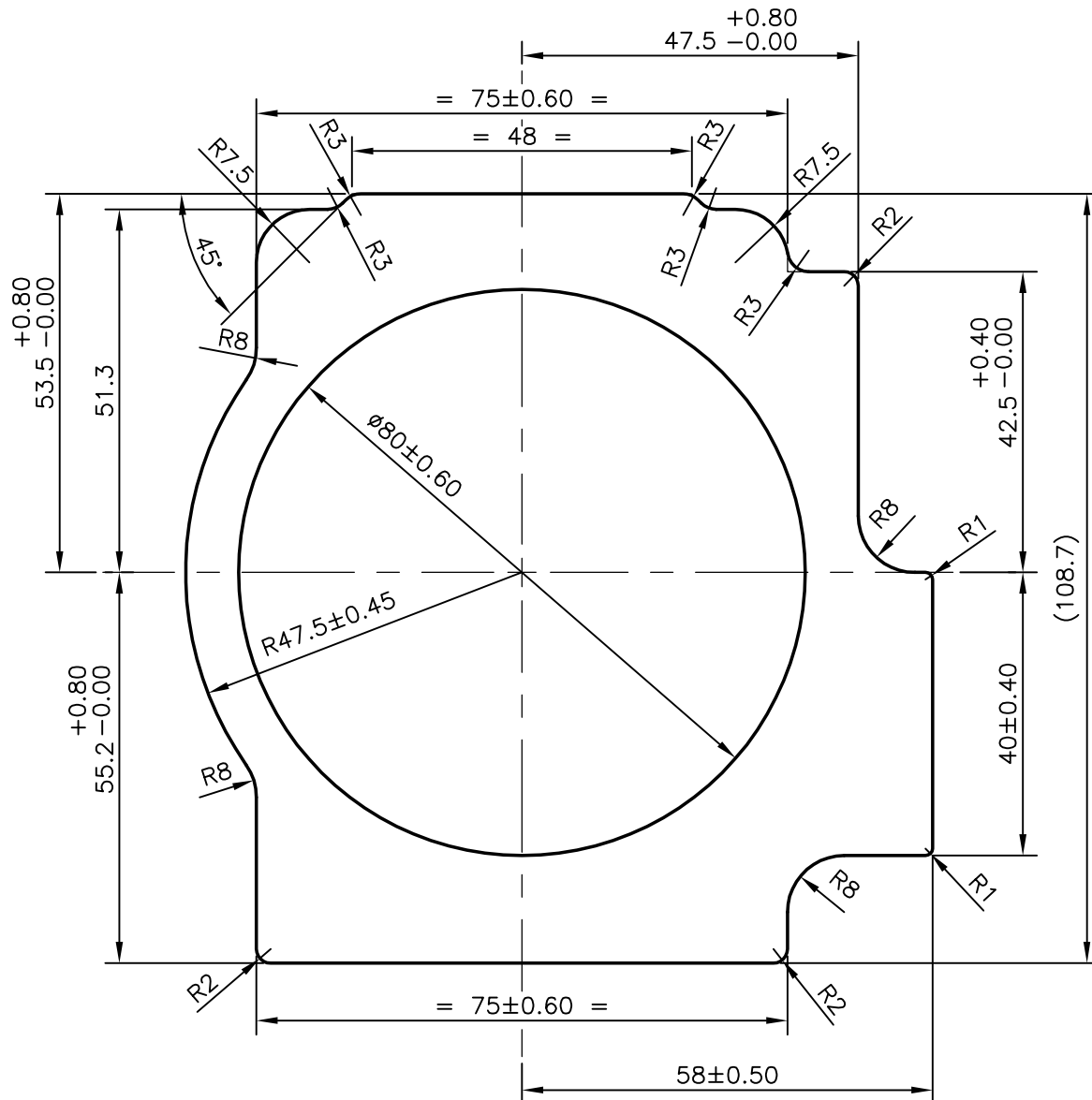

STRAIGHTNESS:- 1.0 mm/Mtr  
 TWIST & BEND:-  $\pm 1.0^\circ$ /M  
 FLATNESS :- 0.50 mm



SYMBOL OF QUALITY  
 AN ISO 9001 COMPANY

**JINDAL ALUMINIUM LTD.**  
 BANGALORE-560073 (INDIA)

	NAME	DATE
DRAWN	MALINGAPPA	29-03-2006
CHECKED		
APPROVED		

1. ALL DIMENSIONS ARE IN mm.
2. ROUND OFF ALL SHARP CORNERS WITH 0.40 mm.
3. TOLERANCES WILL BE AS PER IS:6477-1983 UNLESS OTHERWISE SPECIFIED

SCALE	1:1
AREA $\text{mm}^2$	4718.64
PERIMETER mm.	391.526
WEIGHT kg/m	12.740

PARTY'S NAME DELVAL FLOW CONTROLS PVT. LTD., PUNE

PARTY'S DRAWING No. 2M.085.BD.x.1.0

ALLOY & TEMPER 6063 T6

DESCRIPTION PUMP BODY

DRAWING No.	SECTION No.
P-6285	-
S1731	S1731
27046	27046