

P-6286

S1732

27047

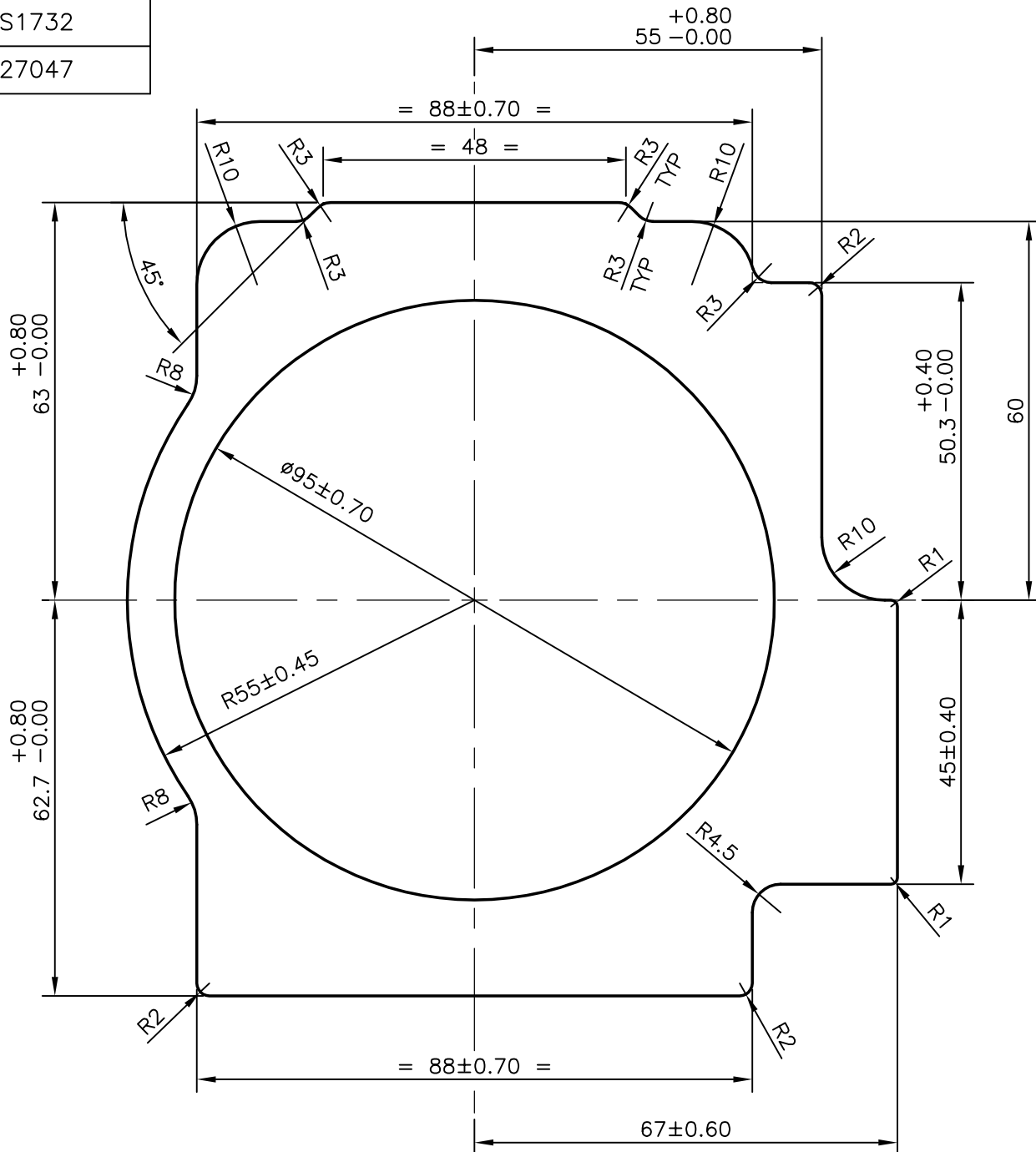

STRAIGHTNESS:- 1.0 mm/Mtr

TWIST & BEND:- $\pm 1.0^\circ$ /M

FLATNESS :- 0.50 mm



SYMBOL OF QUALITY
AN ISO 9001 COMPANY

JINDAL ALUMINIUM LTD.
BANGALORE-560073 (INDIA)

	NAME	DATE
DRAWN	MALINGAPPA	29-03-2006
CHECKED		
APPROVED		

1. ALL DIMENSIONS ARE IN mm.
2. ROUND OFF ALL SHARP CORNERS WITH 0.40 mm.
3. TOLERANCES WILL BE AS PER IS:6477-1983 UNLESS OTHERWISE SPECIFIED

SCALE	1:1
AREA mm ²	5931.795
PERIMETER mm.	454.682
WEIGHT kg/m	16.016

PARTY'S NAME	DELVAL FLOW CONTROLS PVT. LTD., PUNE
--------------	--------------------------------------

PARTY'S DRAWING No.	2M.100.BD.x.1.0
---------------------	-----------------

ALLOY & TEMPER	6063 T6
----------------	---------

DESCRIPTION	PUMP BODY
-------------	-----------

DRAWING No.	SECTION No.
P-6286	-
S1732	S1732
27047	27047