

P-6335-1

S1789

27069

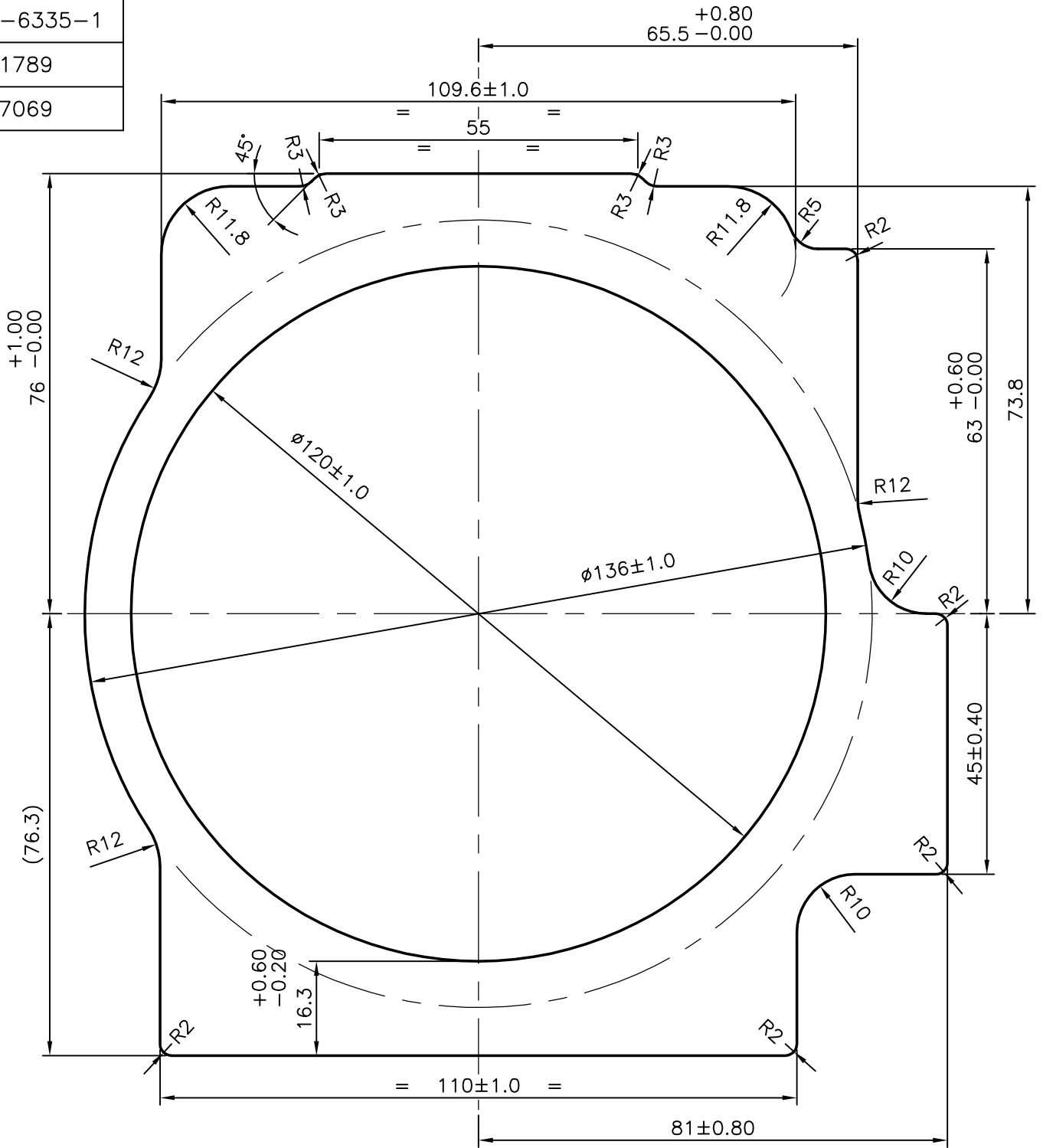

STRAIGHTNESS:- 1.0 mm/Mtr  
 TWIST & BEND:- ±1.0°/M  
 FLATNESS :- 0.50 mm



SYMBOL OF QUALITY  
 AN ISO 9001 COMPANY

**JINDAL ALUMINIUM LTD.**  
 BANGALORE-560073 (INDIA)

	NAME	DATE
DRAWN	MALINGAPPA	21-04-2006
CHECKED		
APPROVED		

1. ALL DIMENSIONS ARE IN mm.
2. ROUND OFF ALL SHARP CORNERS WITH 0.40 mm.
3. TOLERANCES WILL BE AS PER IS:6477-1983 UNLESS OTHERWISE SPECIFIED

SCALE	1:1
AREA mm <sup>2</sup>	7868.107
PERIMETER mm.	552.579
WEIGHT kg/m	21.244

PARTY'S NAME	DELVAL FLOW CONTROLS PVT. LTD., PUNE
PARTY'S DRAWING No.	2M.125.BD.x.1.0
ALLOY & TEMPER	6063 T6
DESCRIPTION	PUMP BODY

DRAWING No.	SECTION No.
P-6335-1	-
S1789	S1789
27069	27069