

P-6193
S1719
27074

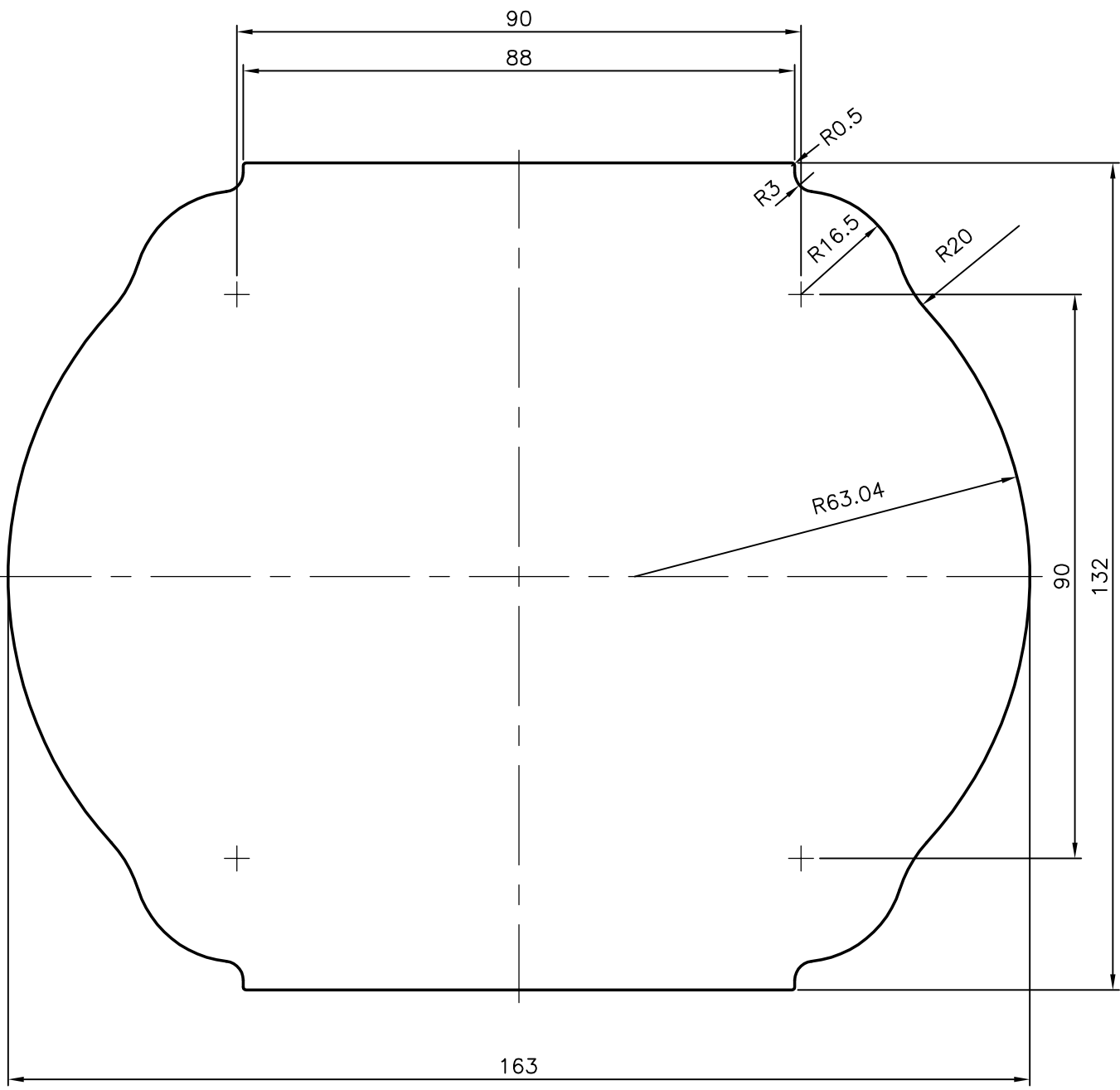

JINDAL ALUMINIUM LTD.
BANGALORE-560073 (INDIA)

	NAME	DATE
DRAWN	J.P.KAUSHIK	11-02-2006
CHECKED		
APPROVED		
SCALE		1:1
AREA mm ²		18250.388
PERIMETER mm.		497.148
WEIGHT kg/m		49.276
DRAWING No.	SECTION No.	
P-6193	-	
S1719	S1719	
27074	27074	

1. ALL DIMENSIONS ARE IN mm.
2. ROUND OFF ALL SHARP CORNERS WITH 0.40 mm.
3. TOLERANCES WILL BE AS PER IS:3965-1981 UNLESS OTHERWISE SPECIFIED

PARTY'S NAME	PAMA HYDRO PARTS PVT. LTD., AHMEDABAD
PARTY'S DRAWING No.	013PAL
ALLOY & TEMPER	HE30 WP
DESCRIPTION	PUMP BODY