

P-6287

S1733

27075

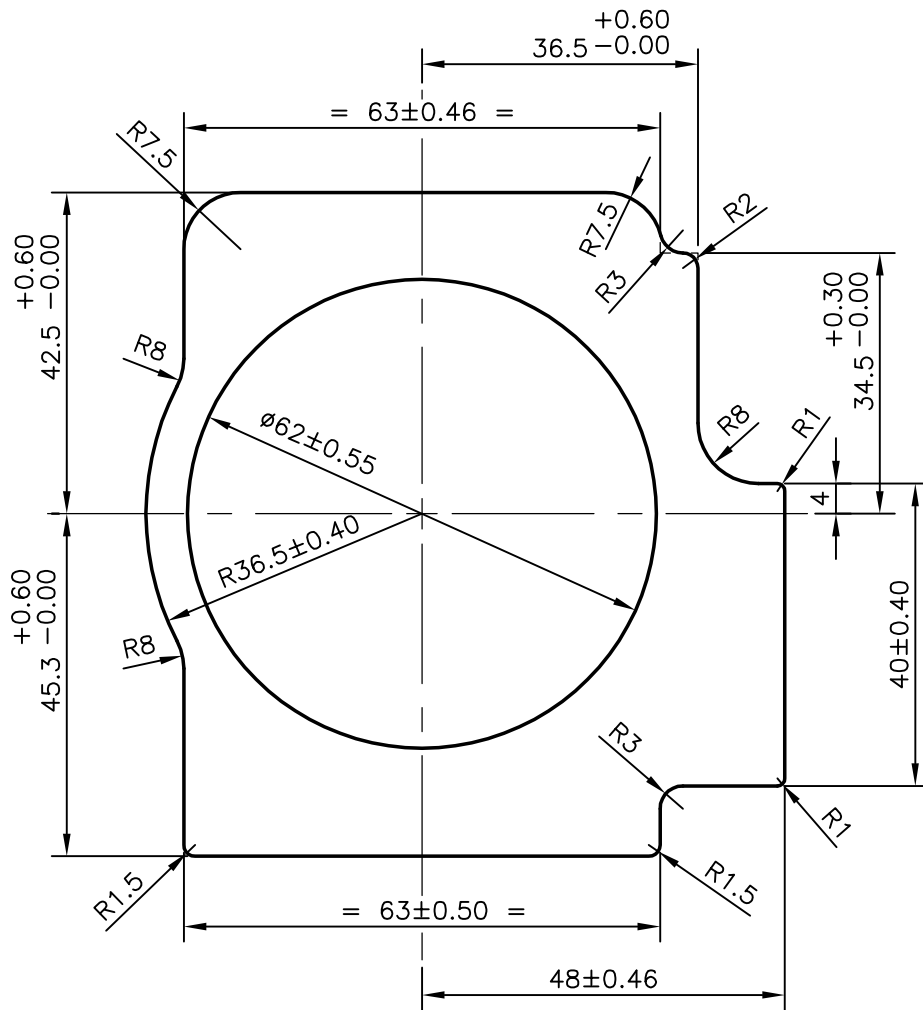

STRAIGHTNESS:- 1.0 mm/Mtr

TWIST & BEND:- $\pm 1.0^\circ$ /M

FLATNESS :- 0.50 mm



SYMBOL OF QUALITY
AN ISO 9001 COMPANY

JINDAL ALUMINIUM LTD.
BANGALORE-560073 (INDIA)

	NAME	DATE
DRAWN	MALINGAPPA	29-03-2006
CHECKED		
APPROVED		

1. ALL DIMENSIONS ARE IN mm.
2. ROUND OFF ALL SHARP CORNERS WITH 0.40 mm.
3. TOLERANCES WILL BE AS PER IS:6477-1983 UNLESS OTHERWISE SPECIFIED

SCALE	1:1
AREA mm ²	3443.242
PERIMETER mm.	321.034
WEIGHT kg/m	9.297

PARTY'S NAME DELVAL FLOW CONTROLS PVT. LTD., PUNE

DRAWING No. SECTION No.

PARTY'S DRAWING No. 2M.065.BD.x.1.0

P-6287

-

ALLOY & TEMPER 6063 T6

S1733

S1733

DESCRIPTION

PUMP BODY

27075

27075