

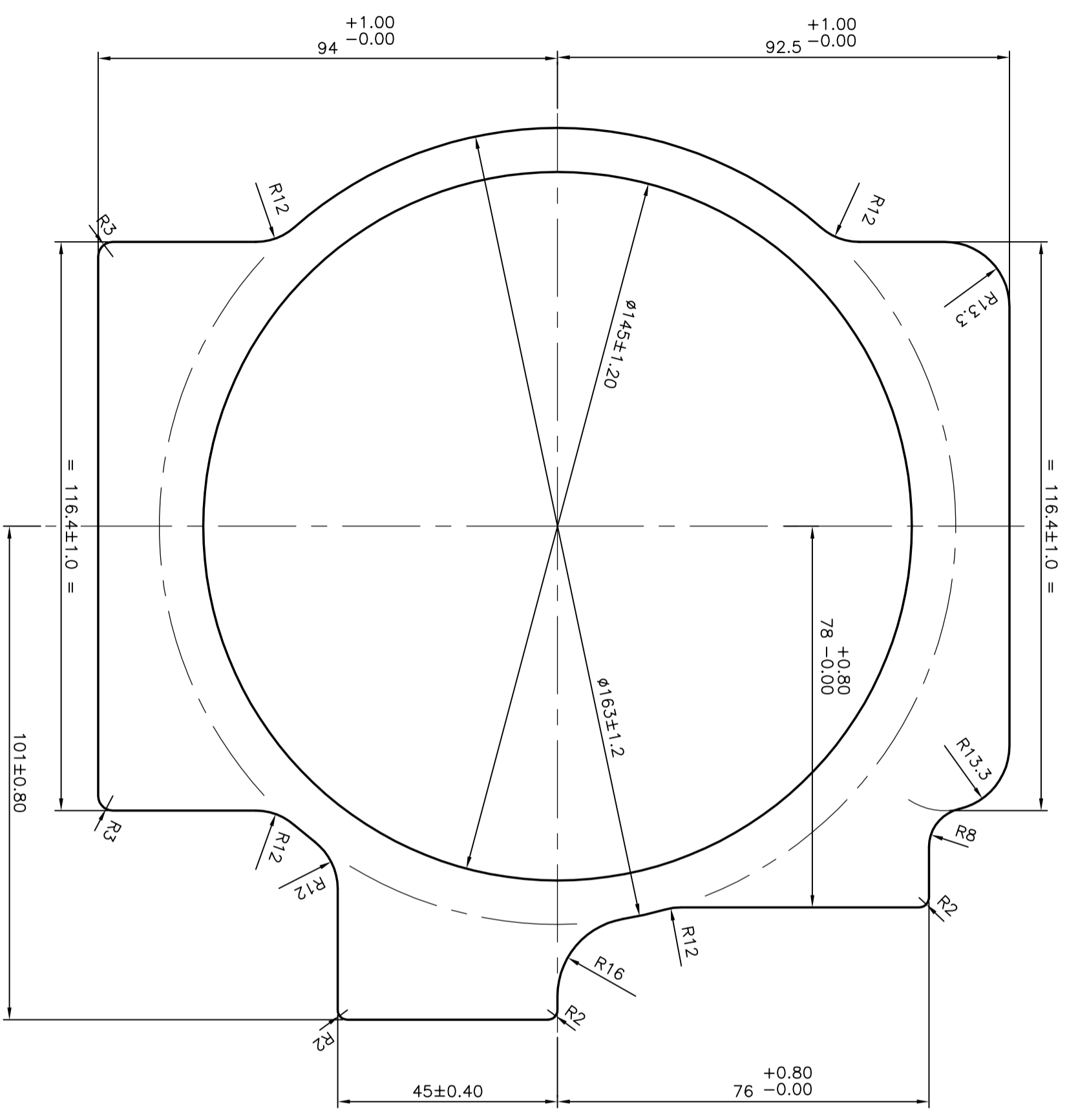

P-6360-4
S1826
27078



STRAIGHTNESS:- 1.0 mm/Mtr
 TWIST & BEND:- ±1.0°/M
 FLATNESS :- 0.50 mm

 SYMBOL OF QUALITY AN ISO 9001 COMPANY		JINDAL ALUMINIUM LTD. BANGALORE-560073 (INDIA)	
1. ALL DIMENSIONS ARE IN mm. 2. ROUND OFF ALL SHARP CORNERS WITH 0.40 mm. 3. TOLERANCES WILL BE AS PER IS:6477-1983 UNLESS OTHERWISE SPECIFIED			
PARTY'S NAME	DELVAL FLOW CONTROLS PVT. LTD., PUNE		
PARTY'S DRAWING No.	2M.150.BD.X.1.0		
ALLOY & TEMPER	6063 T6		
DESCRIPTION	PUMP BODY		
SCALE	1:1		
AREA mm ²	10557.995		
PERIMETER mm.	666.853		
WEIGHT kg/m	28.507		
DRAWING No.	SECTION No.		
P-6360-4	-		
S1826	S1826		
27078	27078		
DATE	12-08-2006		
NAME	j.p.kushik		
CHECKED			
APPROVED			