

P-11659-2

S3254

27107

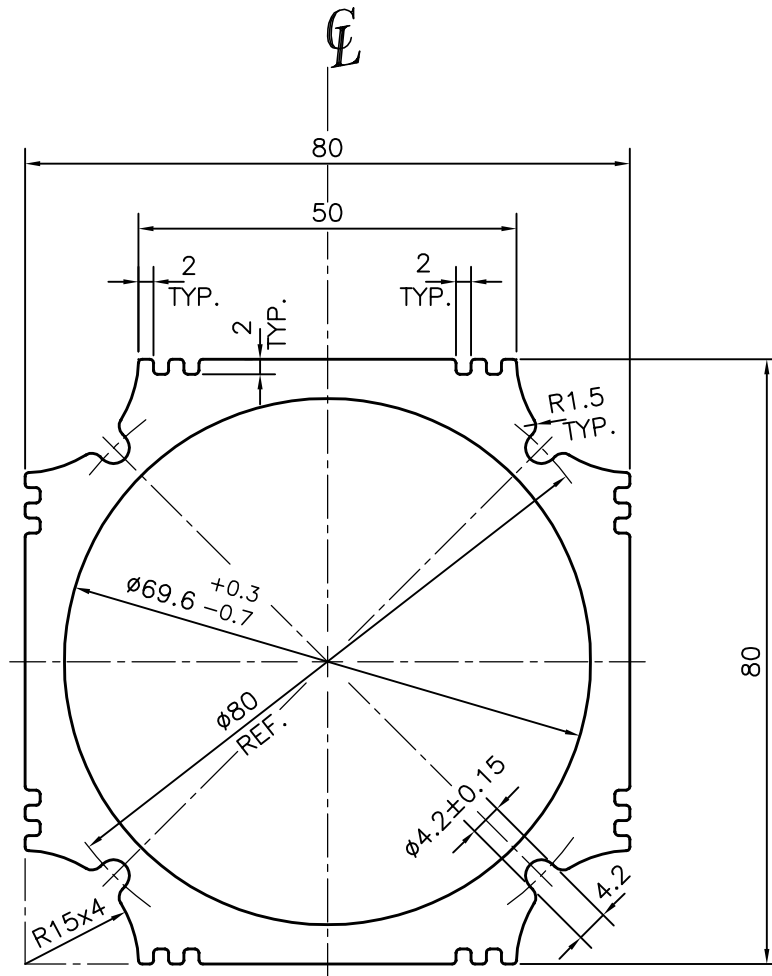

NOTE:-

OVALITY ON $\phi 69.6$ mm.:- ± 0.70 mm.



SYMBOL OF QUALITY
AN ISO 9001 COMPANY

JINDAL ALUMINIUM LTD.
BANGALORE-560073 (INDIA)

	NAME	DATE
DRAWN	PARVESH	17-04-2012
CHECKED		
APPROVED	S.S.GARG	19-04-2012
SCALE		1:1
AREA mm ²		1766.838
PERIMETER mm.		362.794
WEIGHT kg/m		4.77
DRAWING No.	SECTION No.	
P-11659-2	-	
S3254	S3254	
27107	27107	

1. ALL DIMENSIONS ARE IN mm.
2. ROUND OFF ALL SHARP CORNERS WITH 0.50 mm.
3. TOLERANCES WILL BE AS PER IS:6477-1983, UNLESS OTHERWISE SPECIFIED

PARTY'S NAME	COMPAGE AUTOMATION SYSTEMS PVT. LTD., FARIDABAD
PARTY'S DRAWING No.	AS PER DRAWING
ALLOY & TEMPER	6063 T6
DESCRIPTION	PUMP BODY SECTION