

P-11551

S3201

27108

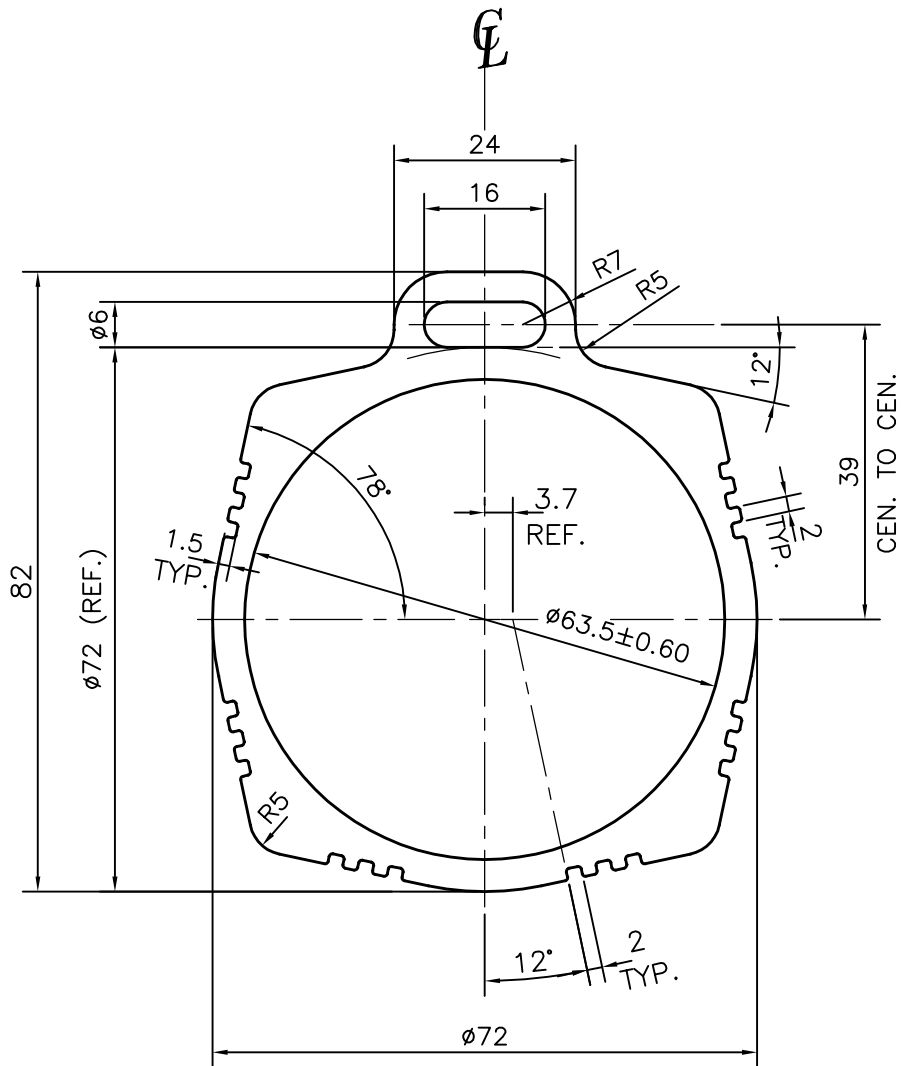

SYMBOL OF QUALITY  
AN ISO 9001 COMPANY

**JINDAL ALUMINIUM LTD.**  
BANGALORE-560073 (INDIA)

	NAME	DATE
DRAWN	PARVESH	06-02-2012
CHECKED		
APPROVED	S.S.GARG	27-02-2012
SCALE		1:1
AREA mm <sup>2</sup>		1376.492
PERIMETER mm.		300.639
WEIGHT kg/m		3.717
DRAWING No.	SECTION No.	
P-11551		
S3201	S3201	
27108	27108	

1. ALL DIMENSIONS ARE IN mm.
2. ROUND OFF ALL SHARP CORNERS WITH 0.40 mm.
3. TOLERANCES WILL BE AS PER IS:6477-1983, UNLESS OTHERWISE SPECIFIED

PARTY'S NAME	PRAGATI AUTOMATION PVT. LTD. BANGALORE
PARTY'S DRAWING No.	CV060302-EXT
ALLOY & TEMPER	HE9 WP
DESCRIPTION	MOTOR HOUSING SECTION