

P-12045

S3486

27111

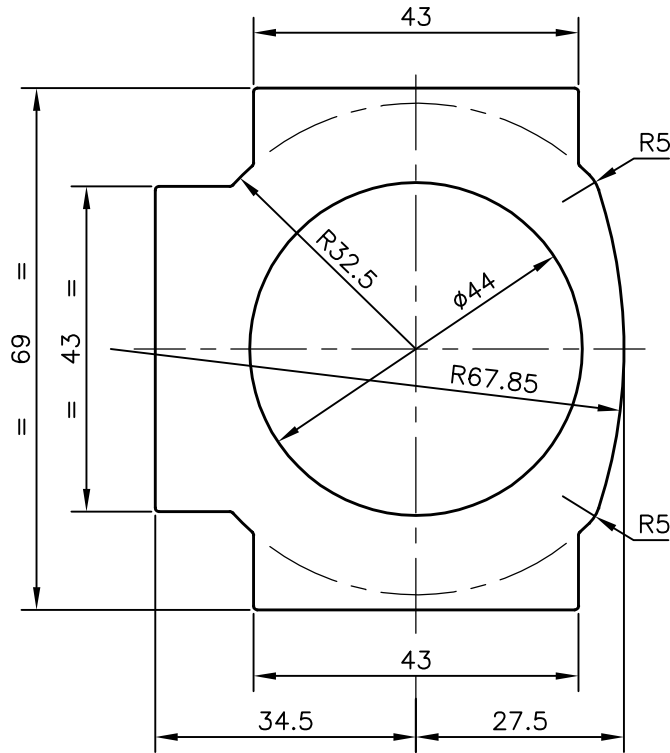

SYMBOL OF QUALITY
AN ISO 9001 COMPANY

JINDAL ALUMINIUM LTD.
BANGALORE-560073 (INDIA)

	NAME	DATE
DRAWN	RAGHAVENDRA	18-09-2012
CHECKED		
APPROVED	S.S.GARG	29-09-2012
SCALE		1:1
AREA mm ²		2230.345
PERIMETER mm.		247.873
WEIGHT kg/m		6.022
DRAWING No.	SECTION No.	
P-12045	-	
S3486	S3486	
27111	27111	

1. ALL DIMENSIONS ARE IN mm.
2. ROUND OFF ALL SHARP CORNERS WITH 0.50 mm.
3. TOLERANCES WILL BE AS PER IS:6477-1983 UNLESS OTHERWISE SPECIFIED

PARTY'S NAME	ANISH ENTERPRISES, THANE
PARTY'S DRAWING No.	NP/50042/AB-001
ALLOY & TEMPER	6063 T6
DESCRIPTION/END USE	ACTUATOR BODY SECTION (50042-NEW)