

P-12588

S3739

27113

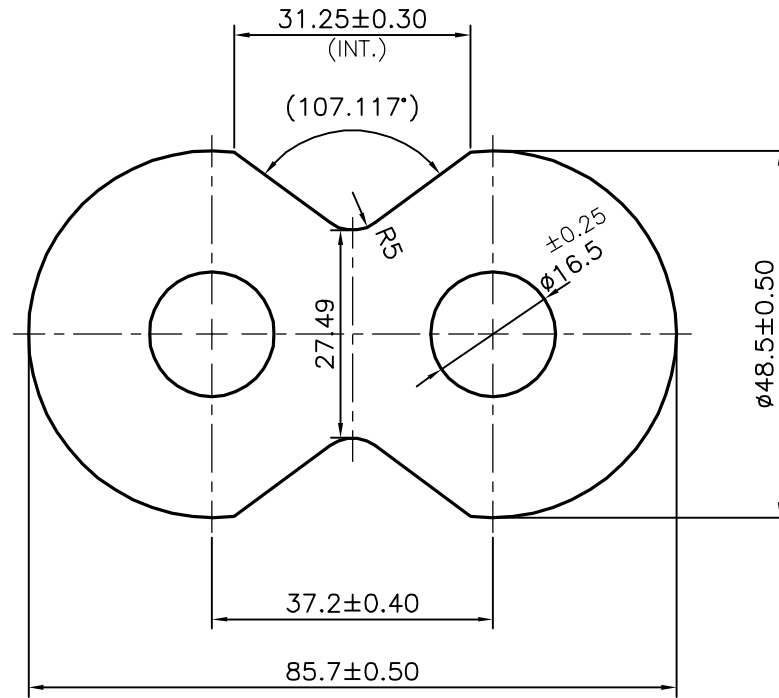

SYMBOL OF QUALITY
AN ISO 9001 COMPANY

JINDAL ALUMINIUM LTD.
BANGALORE-560073 (INDIA)

	NAME	DATE
DRAWN	J.P.KAUSHIK	07-03-2013
CHECKED		
APPROVED	S.S.GARG	10-05-2013

1. ALL DIMENSIONS ARE IN mm.
2. ROUND OFF ALL SHARP CORNERS WITH 0.40 mm.
3. TOLERANCES WILL BE AS PER BS:EN-755-9, UNLESS OTHERWISE SPECIFIED

SCALE	1:1
AREA mm ²	2856.408
PERIMETER mm.	239.923
WEIGHT kg/m	7.712

PARTY'S NAME	GEARED HYDROPOWER PVT. LTD., BELGAUM
PARTY'S DRAWING No.	102 000 006
ALLOY & TEMPER	HE30 WP
DESCRIPTION	BUSH (PUMP BODY)

DRAWING No.	SECTION No.
P-12588	-
S3739	S3739
27113	27113