

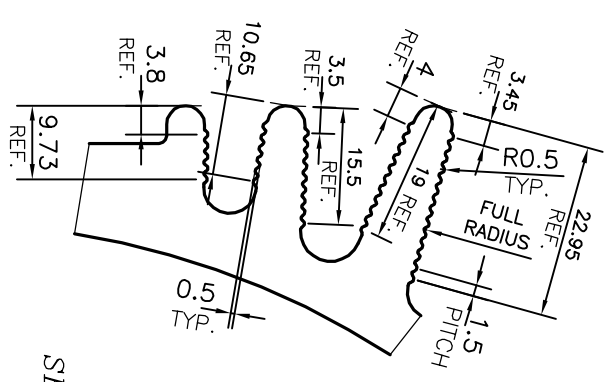

P-13008  
S3861  
27115

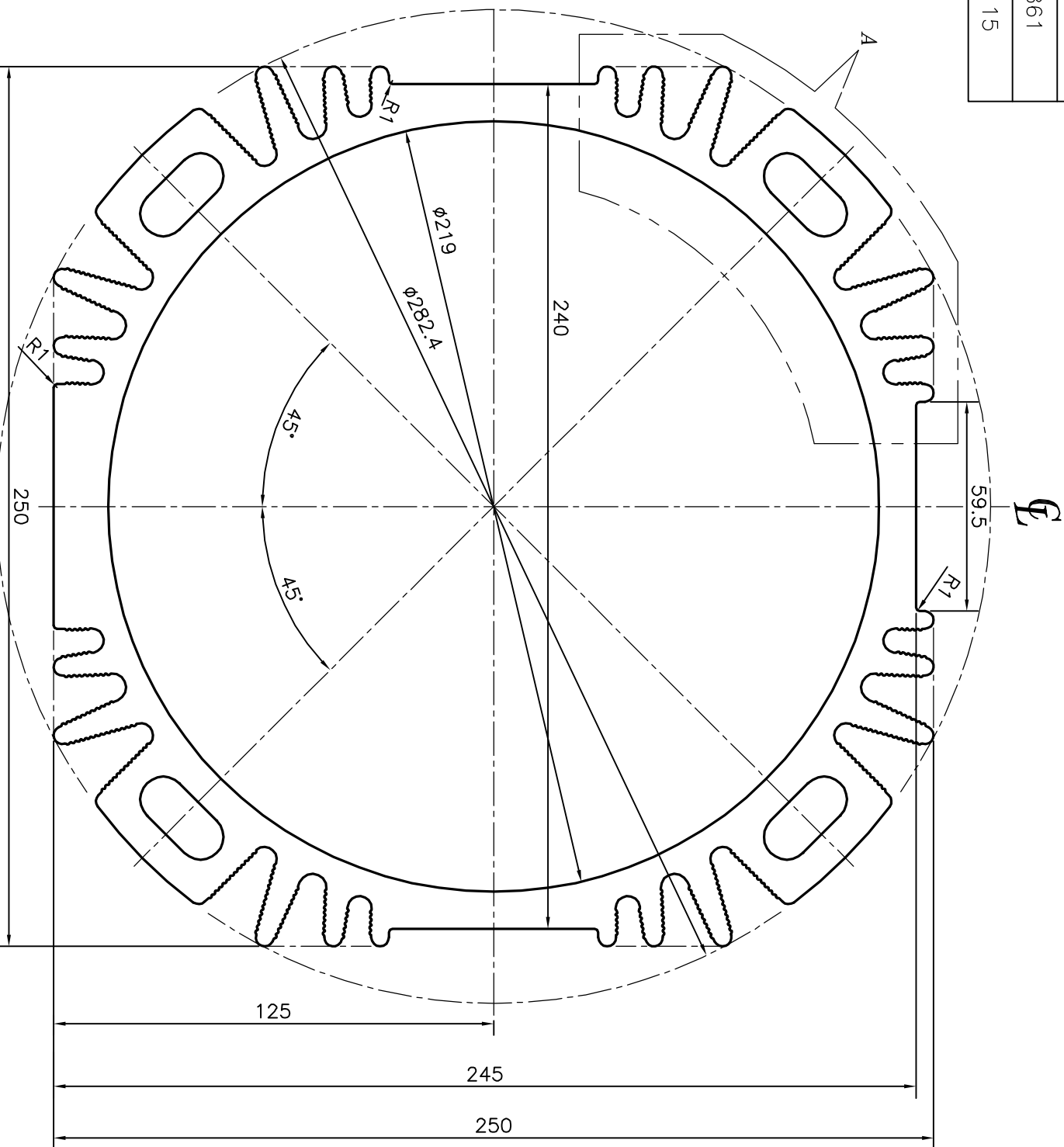

SERRATION DETAIL  
SCALE 1:1

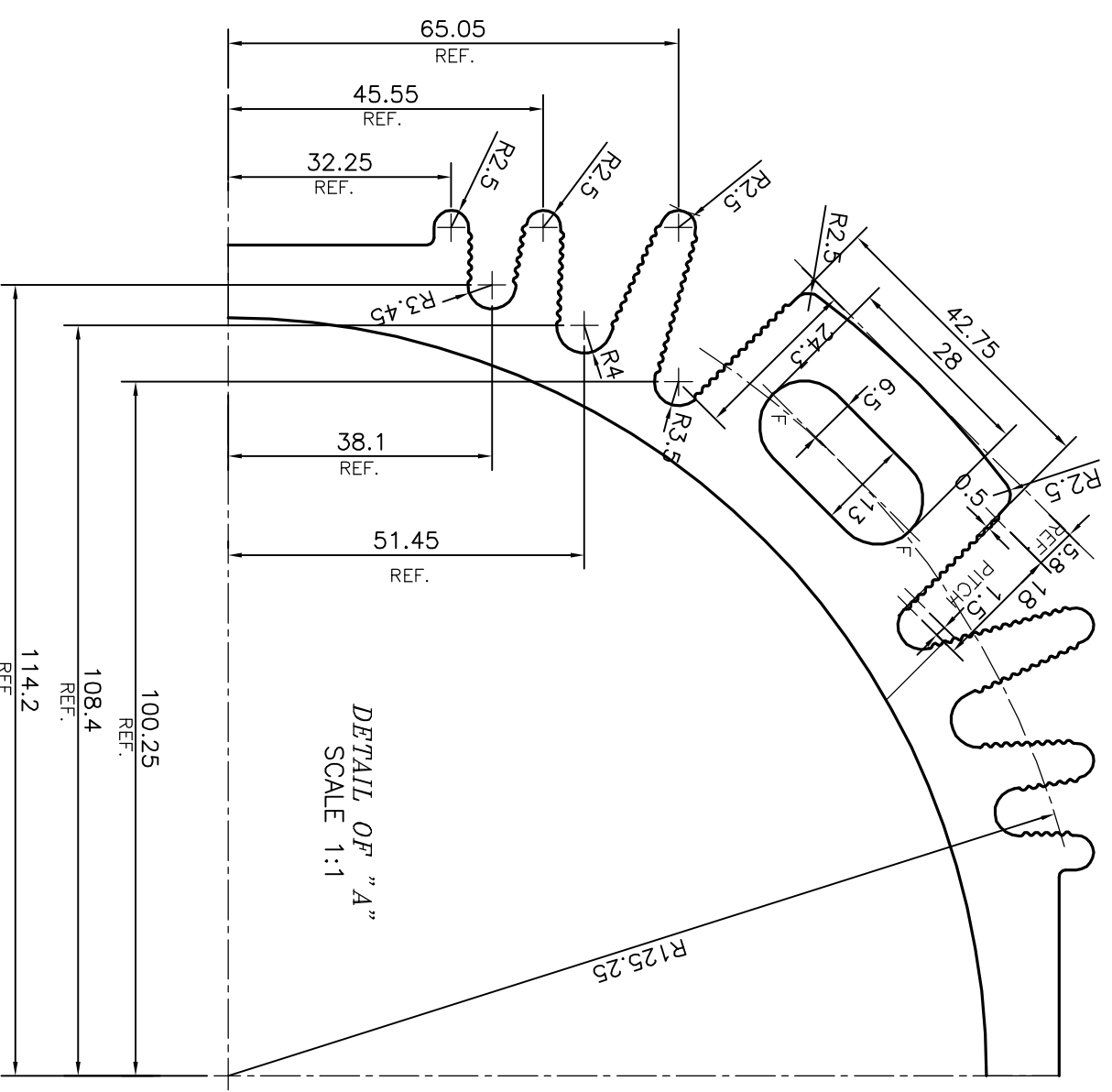

 <b>JINDAL ALUMINIUM LTD.</b> BANGALORE-560073 (INDIA)		DRAWN	NAME	DATE
		CHECKED	PARVESH	12-09-2013
1. ALL DIMENSIONS ARE IN mm. 2. ROUND OFF ALL SHARP CORNERS WITH 1.00 mm. 3. TOLERANCES WILL BE AS PER IS:6477-1983, UNLESS OTHERWISE SPECIFIED		APPROVED	S.S.GARG	17-09-2013
PARTY'S NAME COMPAGE AUTOMATION SYSTEMS PVT. LTD., FARIDABAD		SCALE	0.6:1	
PARTY'S DRAWING No. AS PER AUTOCAD DRAWING- CASPL-CSM-220-001		AREA	12175.835	
ALLOY & TEMPER 6063 T6		PERIMETER	1785.497	
DESCRIPTION MOTOR BODY SECTION		WEIGHT	32.875	
		DRAWING No.	SECTION No.	
		P-13008	-	
		S3861	S3861	
		27115	27115	