

P-16060

S5003

27128

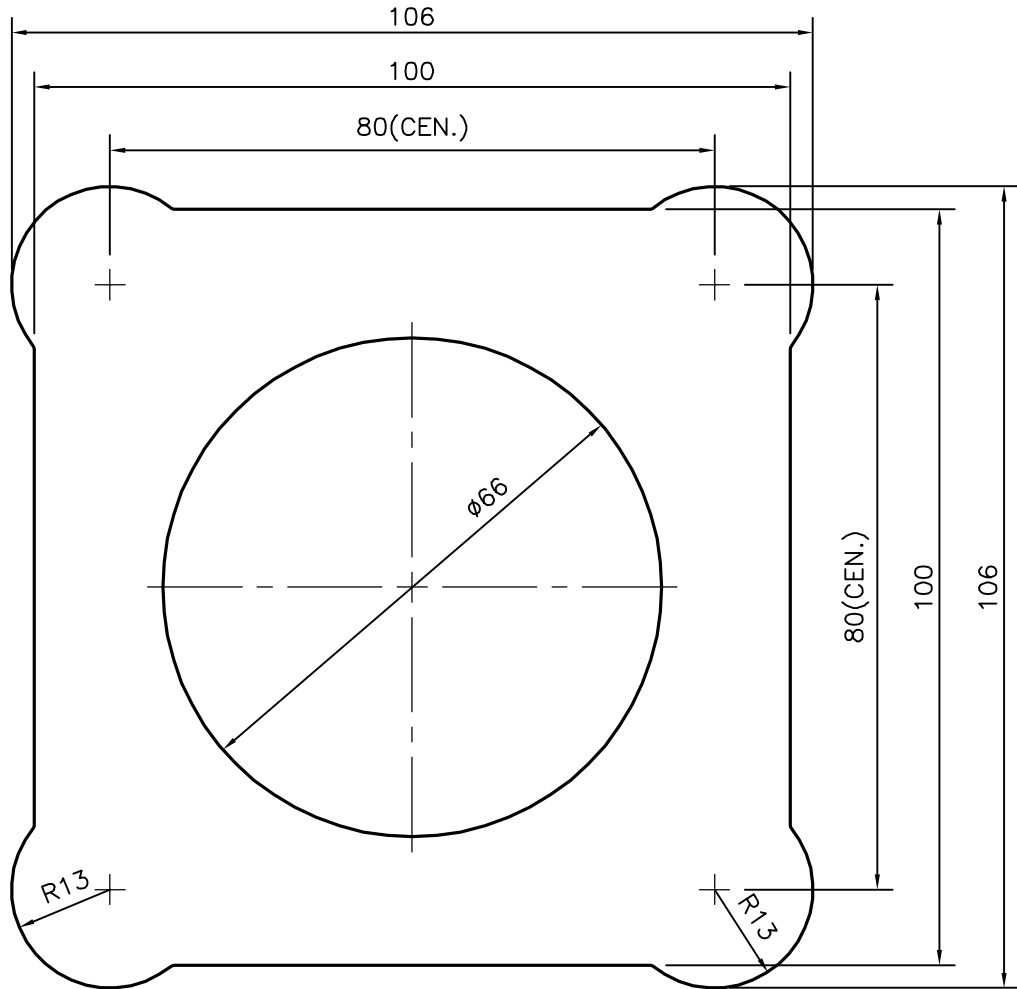

SYMBOL OF QUALITY
AN ISO 9001 COMPANY

JINDAL ALUMINIUM LTD.
BANGALORE-560073 (INDIA)

	NAME	DATE
DRAWN	J.P.KAUSHIK	02-07-2016
CHECKED		
APPROVED	S.S. GARG	07-07-2016
SCALE		1:1
AREA mm ²		6846.064
PERIMETER mm.		407.226
WEIGHT kg/m		18.484
DRAWING No.	SECTION No.	
P-16060	-	
S5003	S5003	
27128	27128	

1. ALL DIMENSIONS ARE IN mm.
2. ROUND OFF ALL SHARP CORNERS WITH 0.40 mm.
3. TOLERANCES WILL BE AS PER IS:6477-1983 UNLESS OTHERWISE SPECIFIED

PARTY'S NAME	GLOBE INDUSTRIAL COMPONENTS, BANGALORE
PARTY'S DRAWING No.	AS PER DRAWING
ALLOY & TEMPER	6082 T6
DESCRIPTION	MISC. SECTION