

P-16813

S5317

27137

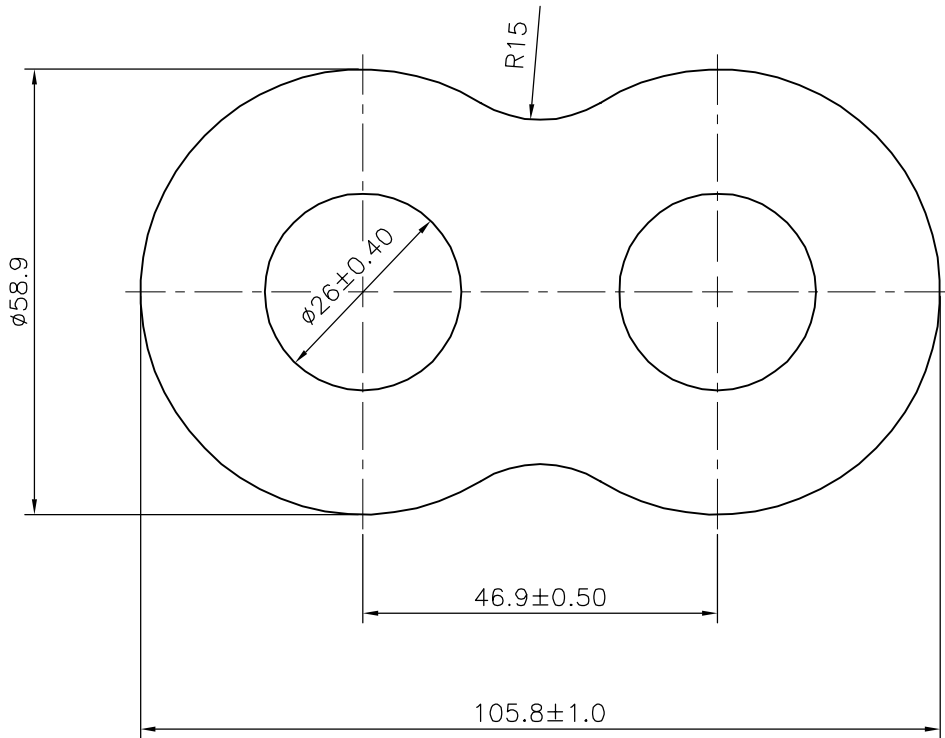

SYMBOL OF QUALITY  
AN ISO 9001 COMPANY

**JINDAL ALUMINIUM LTD.**  
BANGALORE-560073 (INDIA)

	NAME	DATE
DRAWN	J.P.KAUSHIK	10-02-2017
CHECKED		
APPROVED	B.NATARAJ	04-03-2017
SCALE		1:1
AREA mm <sup>2</sup>		4147.735
PERIMETER mm.		283.848
WEIGHT kg/m		11.199
DRAWING No.	SECTION No.	
P-16813	-	
S5317	S5317	
27137	27137	

1. ALL DIMENSIONS ARE IN mm.
2. ROUND OFF ALL SHARP CORNERS WITH 0.40 mm.
3. TOLERANCES WILL BE AS PER IS:6477-1983 UNLESS OTHERWISE SPECIFIED

PARTY'S NAME	SURFINE TOOLS, COIMBATORE
PARTY'S DRAWING No.	AS PER DRAWING-63000006-0002
ALLOY & TEMPER	6082 T6
DESCRIPTION	ACTUATOR BODY SECTION