

P-20081

S6489

27138

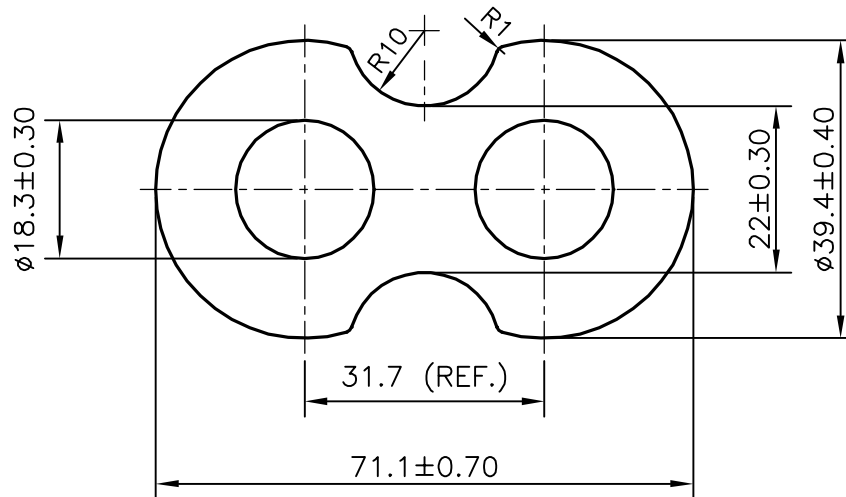

## TOLERANCES ON OVERALL DIMENSIONS OF HOLLOW SECTIONS

UPTO 20.0mm -  $\pm 0.30$   
 UPTO 30.0mm -  $\pm 0.38$   
 UPTO 40.0mm -  $\pm 0.45$   
 UPTO 50.0mm -  $\pm 0.52$   
 UPTO 60.0mm -  $\pm 0.60$

UPTO 80.0mm -  $\pm 0.70$   
 UPTO 100.0mm -  $\pm 0.80$   
 UPTO 120.0mm -  $\pm 0.90$   
 UPTO 140.0mm -  $\pm 1.00$   
 UPTO 160.0mm -  $\pm 1.14$

UPTO 180.0mm -  $\pm 1.27$   
 UPTO 200.0mm -  $\pm 1.40$   
 UPTO 225.0mm -  $\pm 1.52$

1. STRAIGHTNESS=1.7mm/M  
 2. TWIST=1.7mm/M  
 3. ANGULARITY=  $\pm 2^\circ$   
 4. FLATNESS =0.006xWIDTH



SYMBOL OF QUALITY  
 AN ISO 9001 COMPANY

**JINDAL ALUMINIUM LTD.**  
 BANGALORE-560073 (INDIA)

	NAME	DATE
DRAWN	J.P.KAUSHIK	24-08-2019
CHECKED		
APPROVED	B.NATARAJA	26-09-2019

- ALL DIMENSIONS ARE IN mm.
- ROUND OFF ALL SHARP CORNERS WITH 0.40 mm.
- TOLERANCES WILL BE AS PER IS:6477-1983, UNLESS OTHERWISE SPECIFIED

SCALE	1:1
AREA mm <sup>2</sup>	1672.195
PERIMETER mm.	201.912
WEIGHT kg/m	4.515

PARTY'S NAME DIAMOND MANUFACTURING WORKS, ALWAR

DRAWING No.	SECTION No.
P-20081	-
S6489	S6489
27138	27138

PARTY'S DRAWING No. AS PER DRAWING

ALLOY & TEMPER 6066 T6

DESCRIPTION PUMP BODY SECTION