

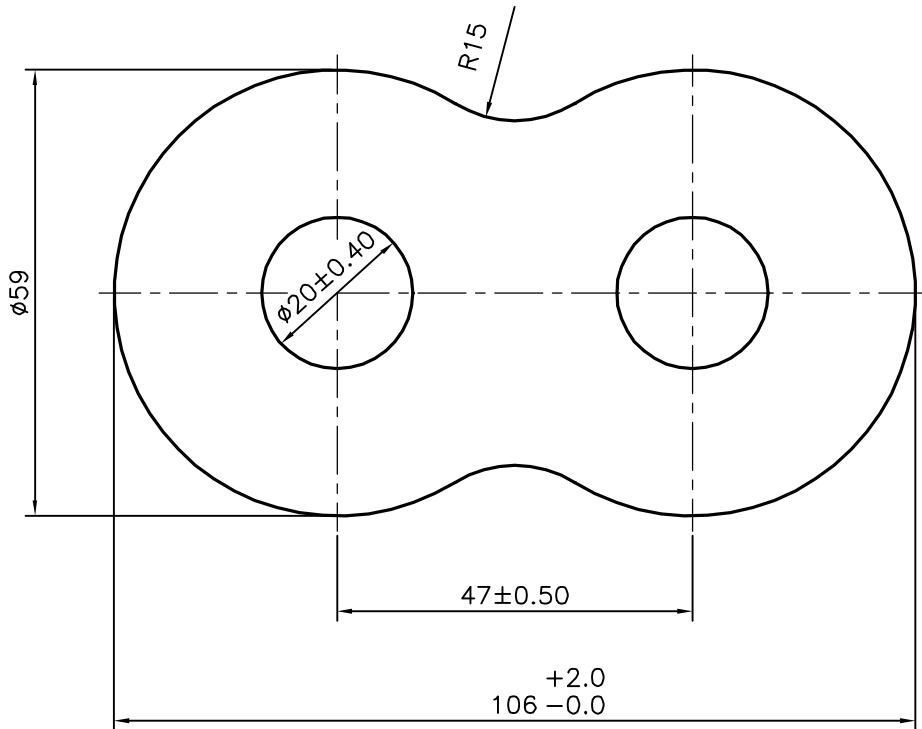

P-17813-1
S5808
27141



 SYMBOL OF QUALITY AN ISO 9001 COMPANY	<b>JINDAL ALUMINIUM LTD.</b> BANGALORE-560073 (INDIA)			NAME	DATE	
		DRAWN	J.P.KAUSHIK	27-04-2018		
1. ALL DIMENSIONS ARE IN mm. 2. ROUND OFF ALL SHARP CORNERS WITH 0.40 mm. 3. TOLERANCES WILL BE AS PER IS:6477-1983 UNLESS OTHERWISE SPECIFIED		CHECKED				
		APPROVED		B.NATARAJA	04-05-2018	
		SCALE		1:1		
PARTY'S NAME		FCS FLUORO CARBON SEALS PVT. LTD., CHENNAI		AREA mm <sup>2</sup>		4599.699
				PERIMETER mm.		284.384
PARTY'S DRAWING No.		MODIFIED OF S5317 & REQUIREMENT		WEIGHT kg/m		12.419
				DRAWING No.	SECTION No.	
ALLOY & TEMPER		6082 T6		P-17813-1	-	
				S5808	S5808	
DESCRIPTION		ACTUATOR BODY SECTION		27141	27141	