

P-4797  
S1184  
27215

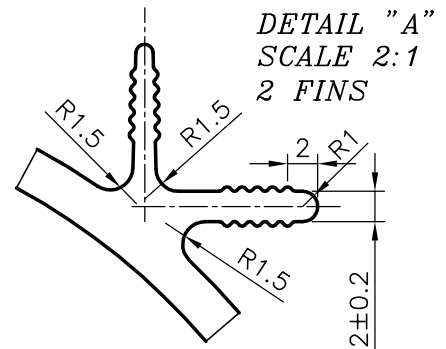

\* = R1 (6 PLACES)

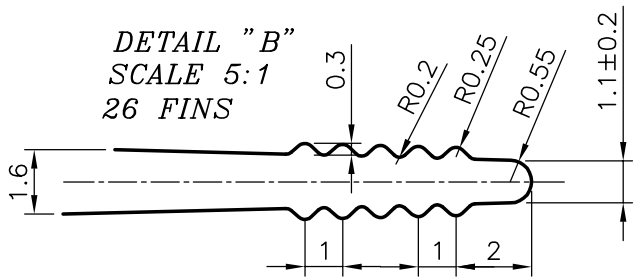
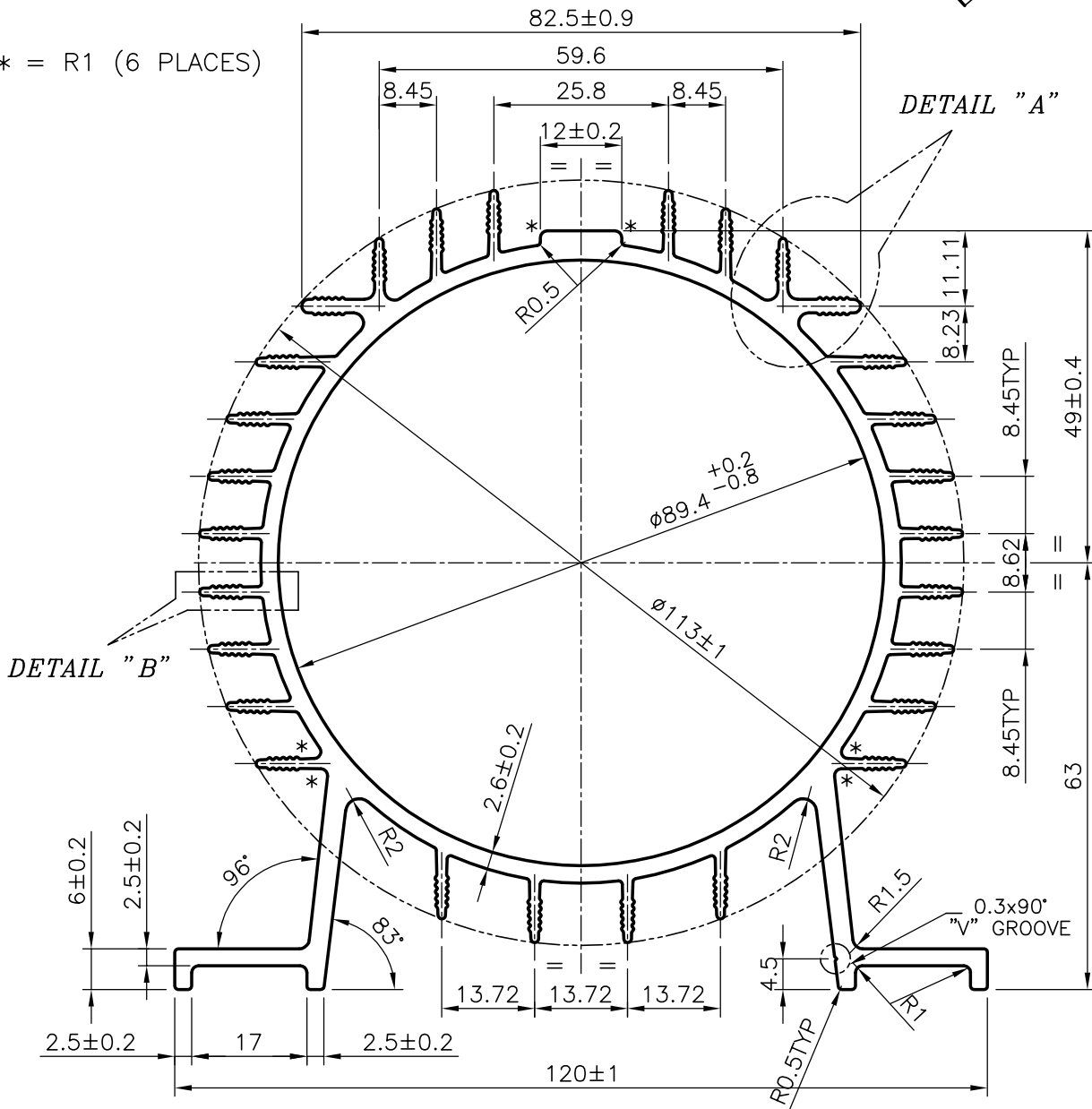

SYMBOL OF QUALITY  
AN ISO 9002 COMPANY

**JINDAL ALUMINIUM LTD.**  
BANGALORE-560073 (INDIA)

	NAME	DATE
DRAWN	RAGHAVENDRA	13-03-2004
CHECKED		
APPROVED		

- ALL DIMENSIONS ARE IN mm.
- ROUND OFF ALL SHARP CORNERS WITH 0.40 mm.
- TOLERANCES WILL BE AS PER IS:6477-1983 UNLESS OTHERWISE SPECIFIED

SCALE	1:1
AREA mm <sup>2</sup>	1541.323
PERIMETER mm.	1064.567
WEIGHT kg/m	4.162

PARTY'S NAME	GANGA ENGG CORPORATION ,, COIMBATORE
PARTY'S DRAWING No.	AS PER DRAWING
ALLOY & TEMPER	HE9 WP
DESCRIPTION	PUMP BODY

DRAWING No.	SECTION No.
P-4797	-
S1184	S1184
27215	27215