

P-4825
S1208
27216

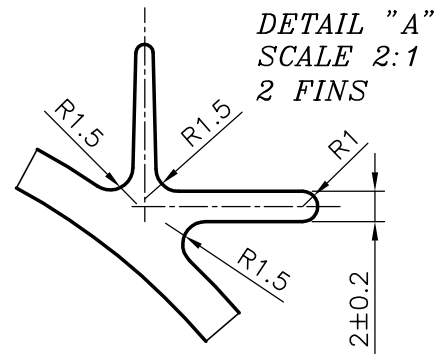

* = R1 (6 PLACES)

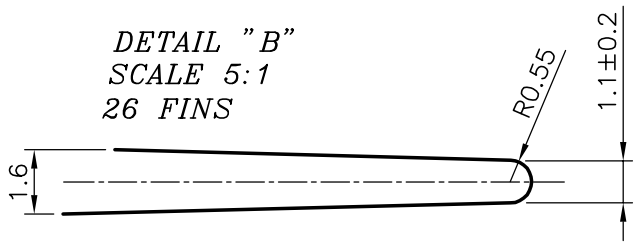
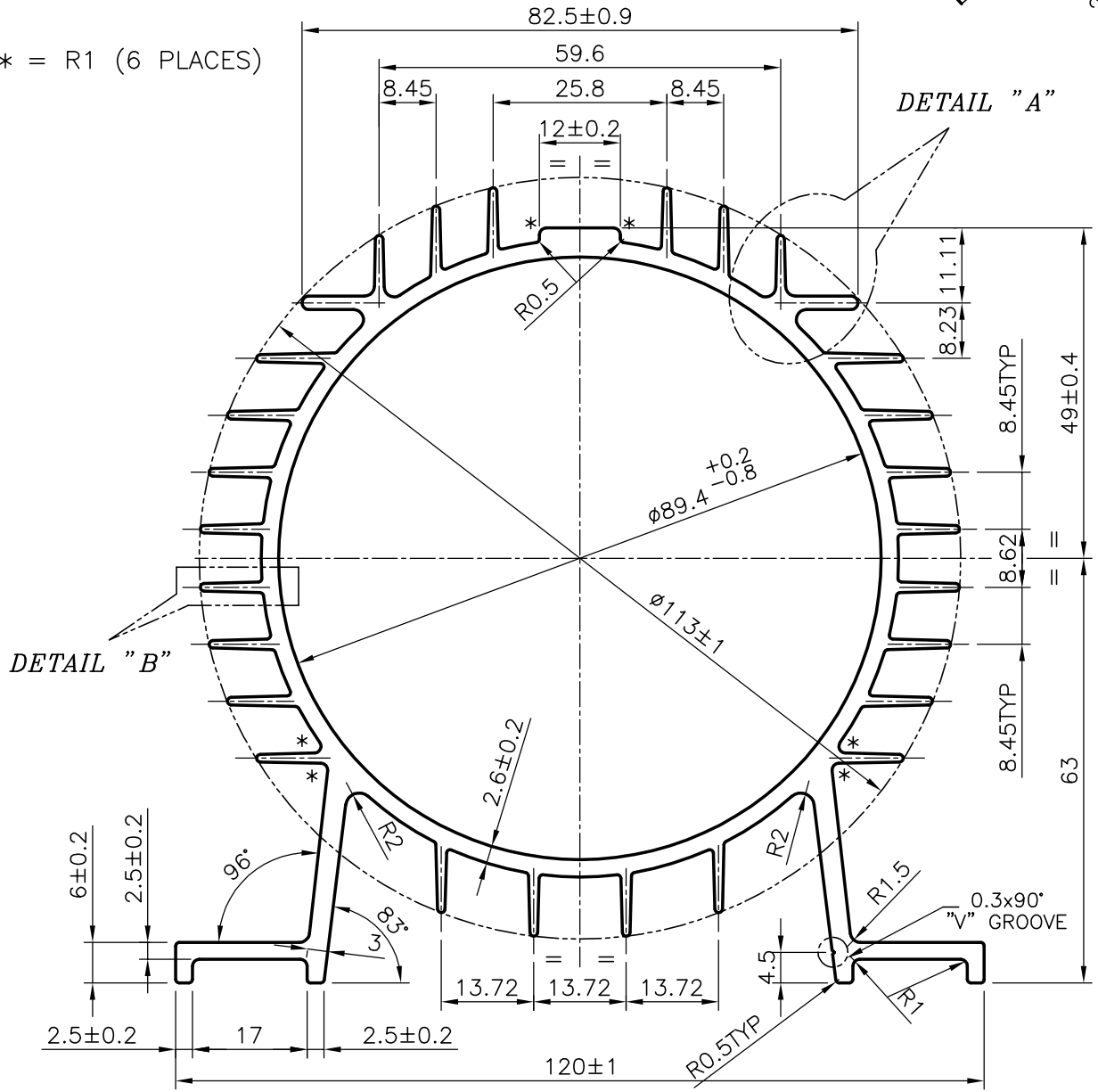

SYMBOL OF QUALITY
AN ISO 9002 COMPANY

JINDAL ALUMINIUM LTD.
BANGALORE-560073 (INDIA)

	NAME	DATE
DRAWN	RAGHAVENDRA	03-04-2004
CHECKED		
APPROVED		

1. ALL DIMENSIONS ARE IN mm.
2. ROUND OFF ALL SHARP CORNERS WITH 0.40 mm.
3. TOLERANCES WILL BE AS PER IS:6477-1983 UNLESS OTHERWISE SPECIFIED

SCALE	1:1
AREA mm ²	1497.908
PERIMETER mm.	1007.952
WEIGHT kg/m	4.044

PARTY'S NAME	GANGA ENGG CORPORATION , COIMBATORE
PARTY'S DRAWING No.	AS PER DRAWING (S1184)
ALLOY & TEMPER	HE9 WP
DESCRIPTION	PUMP BODY

DRAWING No.	SECTION No.
P-4825	-
S1208	S1208
27216	27216