

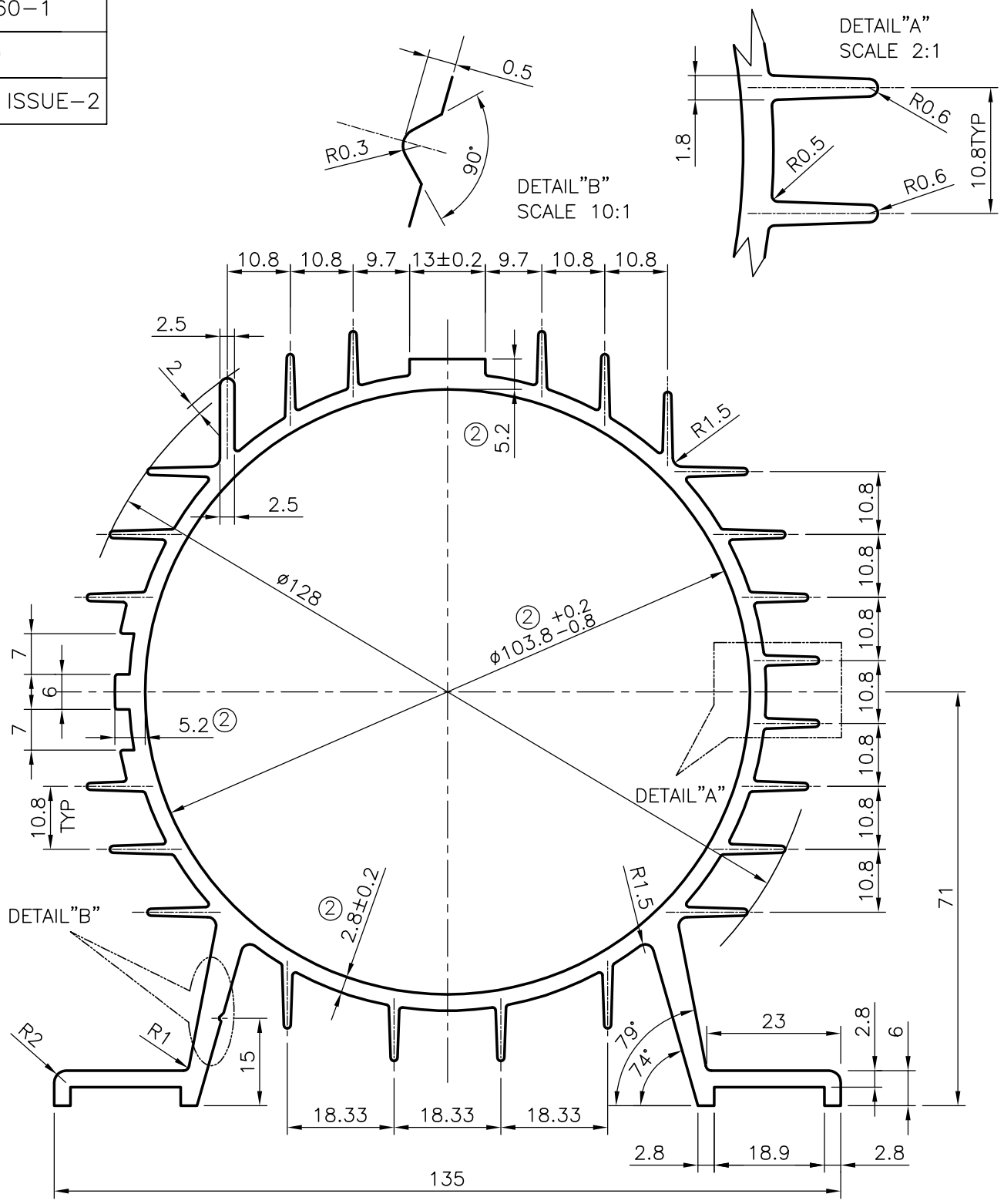

P-4760-1
 S1169
 27217 ISSUE-2



② ISSUE-2

 SYMBOL OF QUALITY AN ISO 9002 COMPANY	JINDAL ALUMINIUM LTD. BANGALORE-560073 (INDIA)	NAME	DATE
		DRAWN	J.P. KAUSHIK 17-09-2005
1. ALL DIMENSIONS ARE IN mm. 2. ROUND OFF ALL SHARP CORNERS WITH 0.40 mm. 3. TOLERANCES WILL BE AS PER IS:6477-1983 UNLESS OTHERWISE SPECIFIED		CHECKED	
		APPROVED	
PARTY'S NAME GANGA ENGG CORPORATION ,, COIMBATORE		SCALE	1:1
		AREA mm ²	1801.676②
PARTY'S DRAWING No. AS PER SAMPLE & AS PER REQUIREMENT		PERIMETER mm.	1022.71 ②
		WEIGHT kg/m	4.865 ②
ALLOY & TEMPER HE9 WP		DRAWING No.	SECTION No.
		P-4760-1	-
DESCRIPTION PUMP BODY		S1169	S1169
		27217	27217 (ISSUE-2)