

P-4749-1
S1195
27219

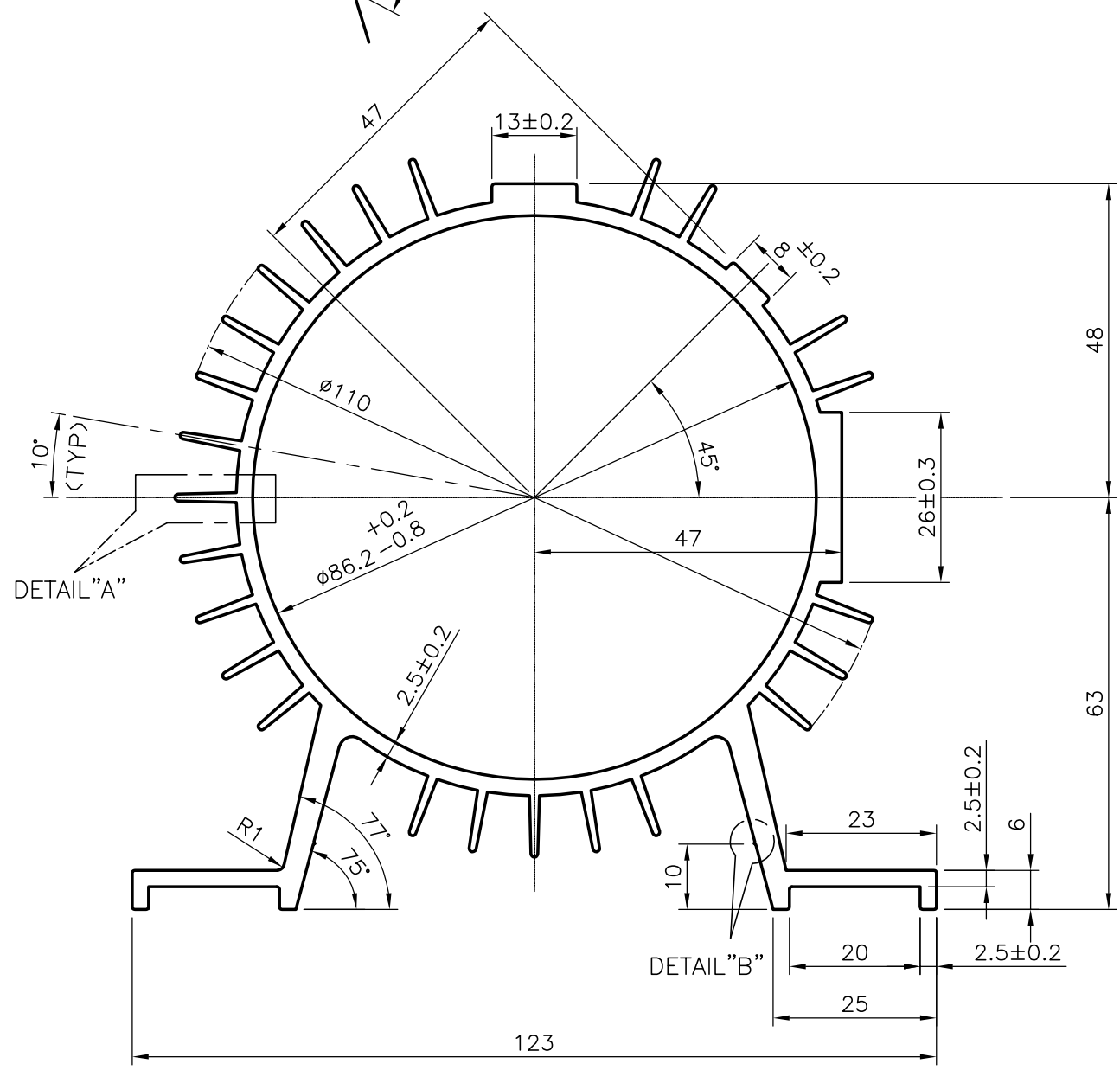
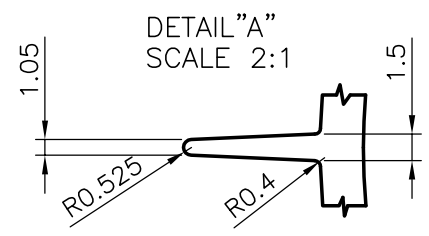
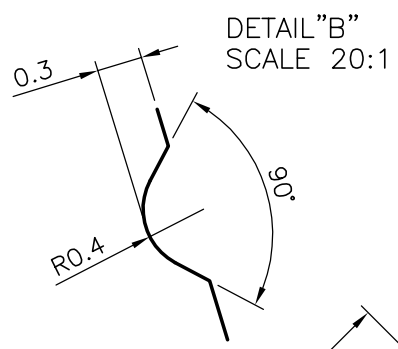

JINDAL ALUMINIUM LTD.
BANGALORE-560073 (INDIA)

	NAME	DATE
DRAWN	RAGHAVENDRA	12-03-2004
CHECKED		
APPROVED		

1. ALL DIMENSIONS ARE IN mm.
2. ROUND OFF ALL SHARP CORNERS WITH 0.40 mm.
3. TOLERANCES WILL BE AS PER IS:6477-1983 UNLESS OTHERWISE SPECIFIED

SCALE	1:1
AREA mm ²	1439.396
PERIMETER mm.	946.397
WEIGHT kg/m	3.886

PARTY'S NAME	GANGA ENGG CORPORATION., COIMBATORE
PARTY'S DRAWING No.	AS PER SAMPLE & AS PER REQUIREMENT
ALLOY & TEMPER	HE9 WP
DESCRIPTION	PUMP BODY

DRAWING No.	SECTION No.
P-4749-1	-
S1195	S1195
27219	27219