

P-5194-2

S1409

27220

DETAIL "B"
SCALE 5:1
26 FINS

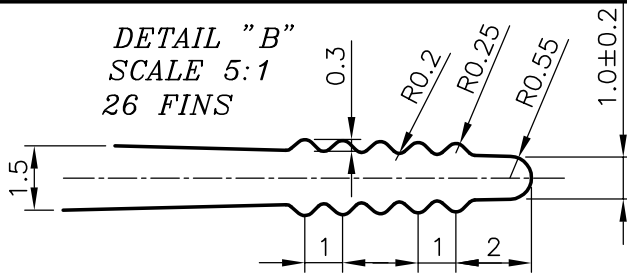

DETAIL "A"
SCALE 2:1
2 FINS

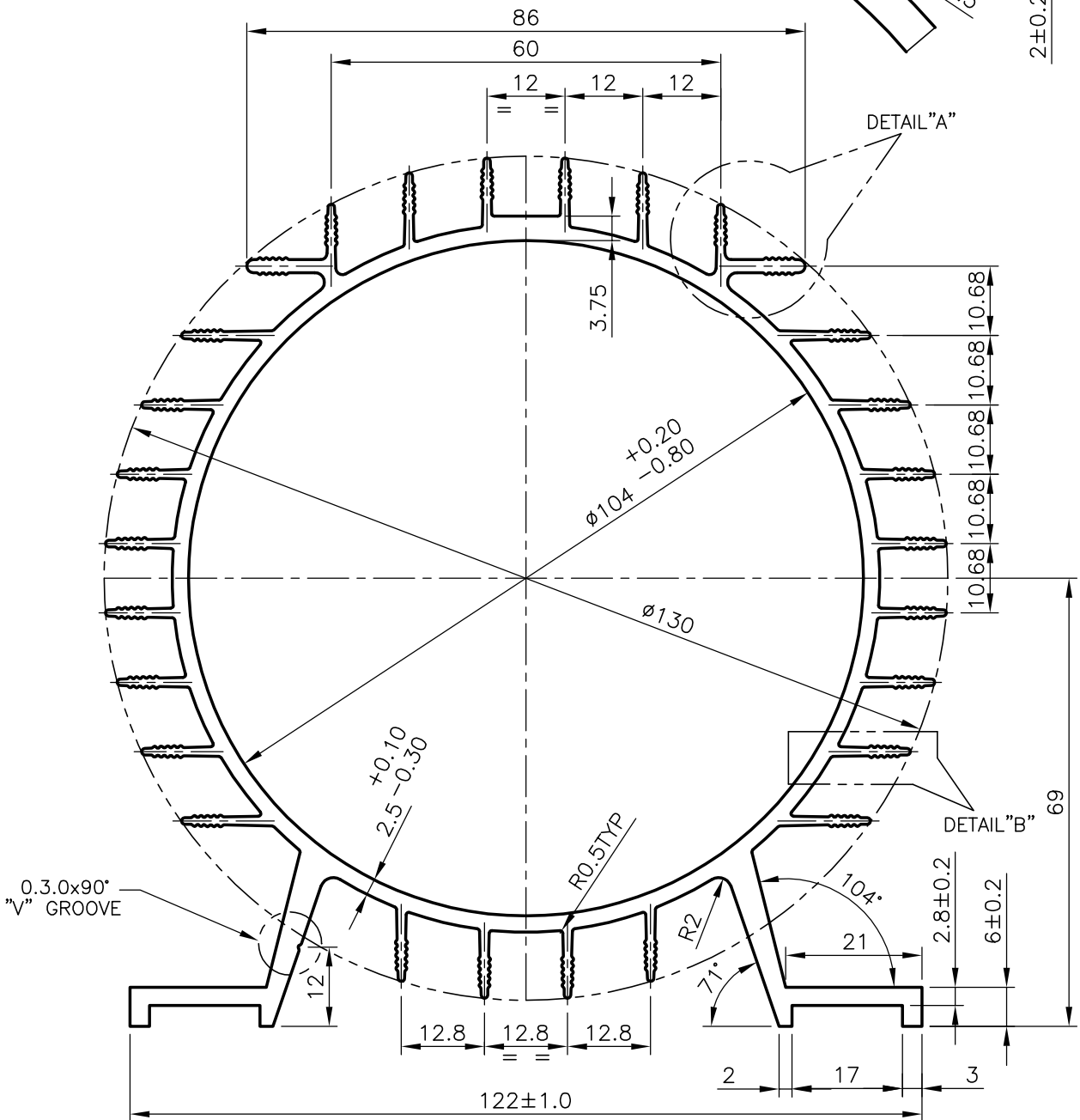
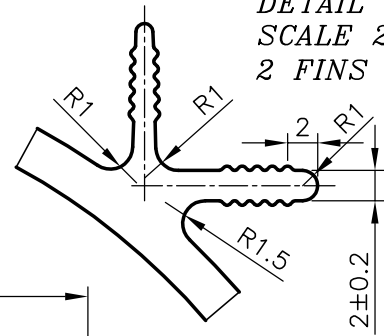

SYMBOL OF QUALITY
AN ISO 9001 COMPANY

JINDAL ALUMINIUM LTD.
BANGALORE-560073 (INDIA)

1. ALL DIMENSIONS ARE IN mm.
2. ROUND OFF ALL SHARP CORNERS WITH 0.50 mm.
3. TOLERANCES WILL BE AS PER IS:6477-1983 UNLESS OTHERWISE SPECIFIED

	NAME	DATE
DRAWN	RAGHAVENDRA	19-01-2005
CHECKED		
APPROVED		
SCALE		1:1
AREA mm ²		1639.355
PERIMETER mm.		1183.64
WEIGHT kg/m		4.426
DRAWING No.	SECTION No.	
P-5194-2	-	
S1409	S1409	
27220	27220	

PARTY'S NAME	GANGA ENGINEERING CORPORATION, COIMBATORE
PARTY'S DRAWING No.	AS PER SAMPLE & AS PER REQUIREMENT
ALLOY & TEMPER	HE9 WP
DESCRIPTION	MOTOR BODY