

P-5865
27226

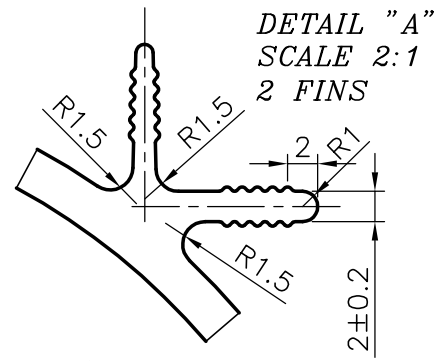

* = R1 (6 PLACES)

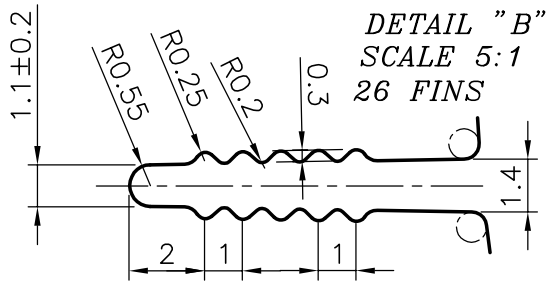
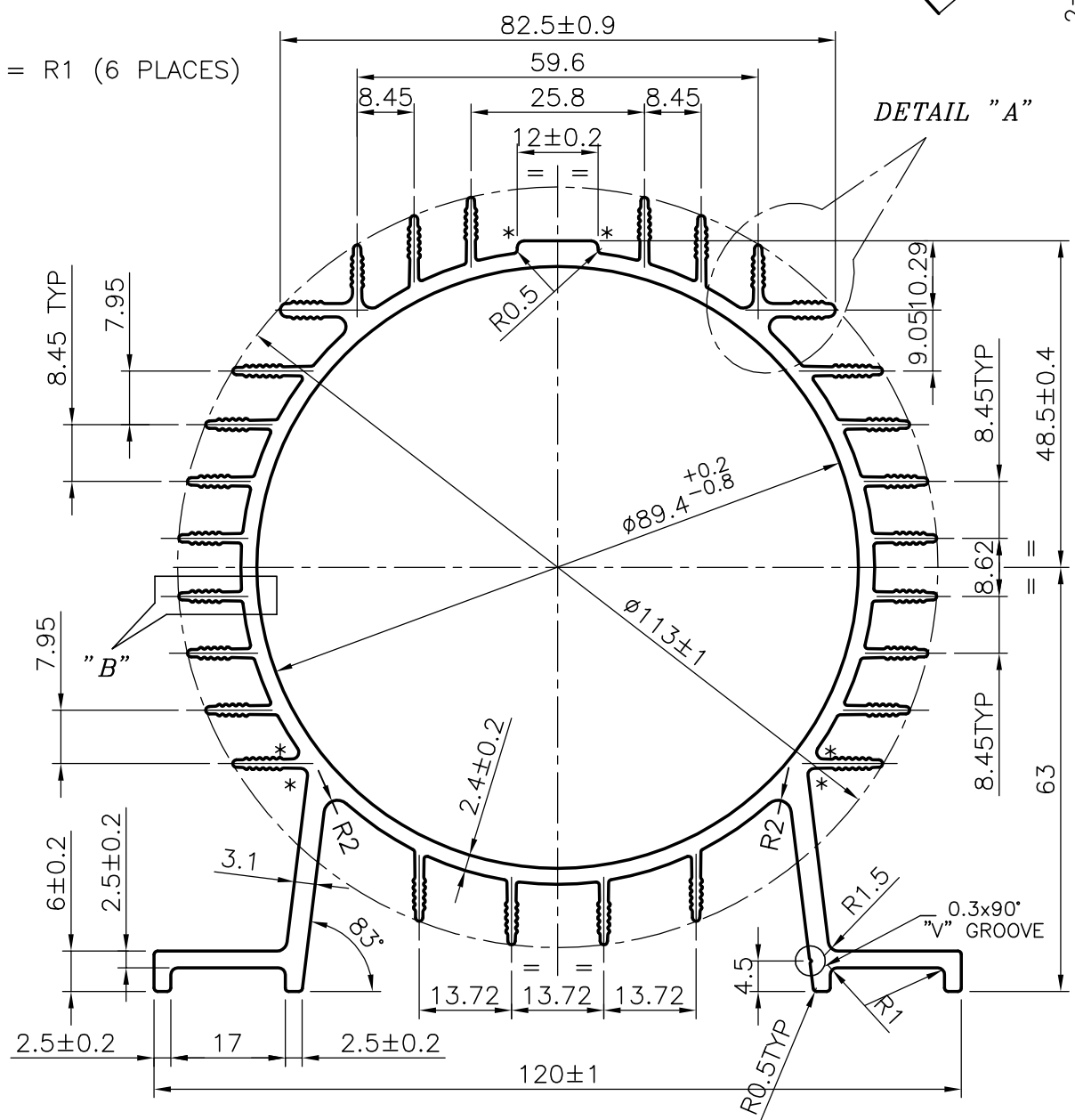

JINDAL ALUMINIUM LTD.
BANGALORE-560073 (INDIA)

	NAME	DATE
DRAWN	MALINGAPPA	14-09-2005
CHECKED		
APPROVED		

1. ALL DIMENSIONS ARE IN mm.
2. ROUND OFF ALL SHARP CORNERS WITH 0.40 mm.
3. TOLERANCES WILL BE AS PER IS:6477-1983 UNLESS OTHERWISE SPECIFIED

SCALE	1:1
AREA mm ²	1462.071
PERIMETER mm.	1085.171
WEIGHT kg/m	3.948

PARTY'S NAME	GENERAL CATEGORY ,, COIMBATORE MARKET
PARTY'S DRAWING No.	AS PER DRAWING
ALLOY & TEMPER	HE9 WP
DESCRIPTION	MOTOR BODY

DRAWING No.	SECTION No.
P-5865	-
27226	27226