

P-5331-1
S1466
27229

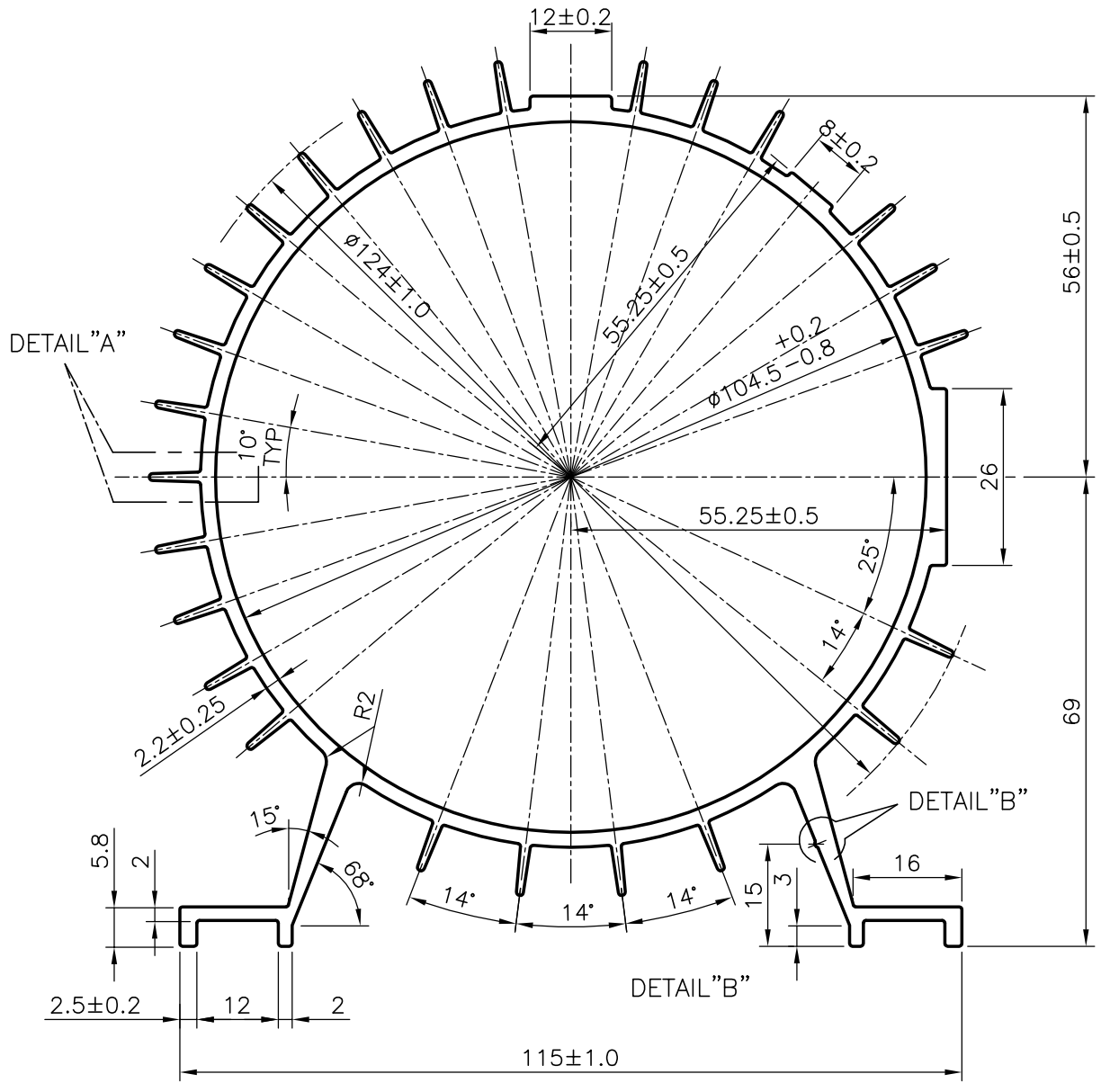
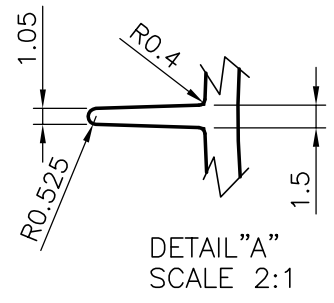
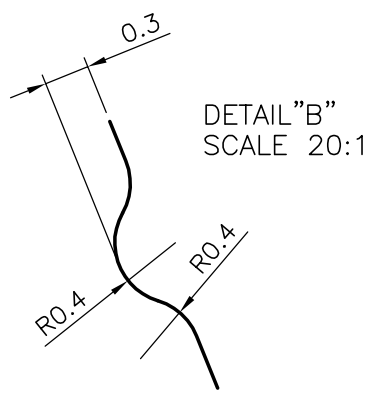

JINDAL ALUMINIUM LTD.
BANGALORE-560073 (INDIA)

	NAME	DATE
DRAWN	MALINGAPPA	13-04-2005
CHECKED		
APPROVED		

1. ALL DIMENSIONS ARE IN mm.
2. ROUND OFF ALL SHARP CORNERS WITH 0.40 mm.
3. TOLERANCES WILL BE AS PER IS:6477-1983 UNLESS OTHERWISE SPECIFIED

SCALE	1:1
AREA mm ²	1270.157
PERIMETER mm.	874.142
WEIGHT kg/m	3.429

PARTY'S NAME	GANGA ENGG CORPORATION., COIMBATORE
PARTY'S DRAWING No.	AS PER DRAWING
ALLOY & TEMPER	HE9 WP
DESCRIPTION	PUMP BODY

DRAWING No.	SECTION No.
P-5331-1	-
S1466	S1466
27229	27229