

P-3667-1

X234

27234

DETAIL "B"  
SCALE 5:1  
26 FINES

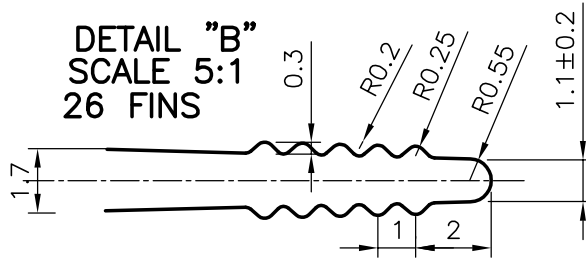

DETAIL "A"  
SCALE 2:1  
2 FINES

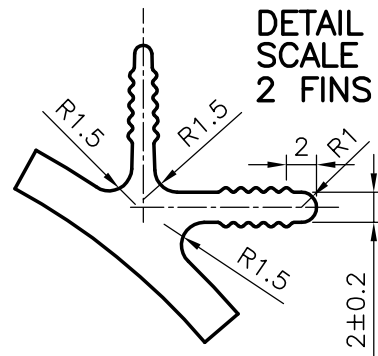

\* = R1 (6 PLACES)

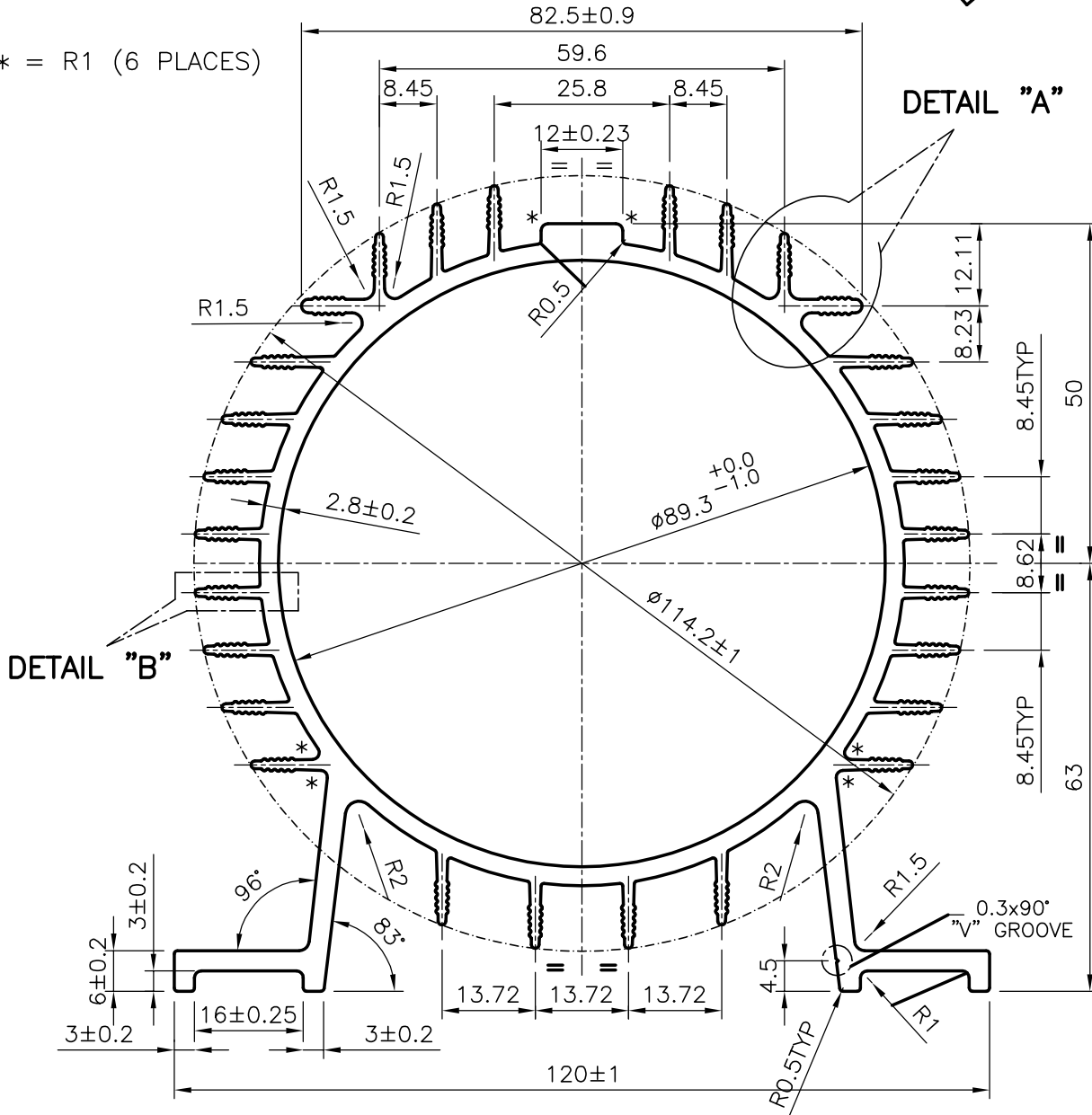

SYMBOL OF QUALITY  
AN ISO 9002 COMPANY

**JINDAL ALUMINIUM LTD.**  
BANGALORE-560073 (INDIA)

	NAME	DATE
DRAWN	RAGHAVENDRA	03-05-02
CHECKED		
APPROVED		

1. ALL DIMENSIONS ARE IN mm.
2. ROUND OFF ALL SHARP CORNERS WITH 0.40 mm.
3. TOLERANCES WILL BE AS PER IS 6477-1983 UNLESS OTHERWISE SPECIFIED

SCALE	1:1
AREA mm <sup>2</sup>	1661.15
PERIMETER	1088.75mm
WEIGHT kg/m	4.485
SECTION No.	27234
DRAWING No.	27234

PARTY'S NAME	GANGA ENGINEERING CORPORATION ., COIMBATORE
PARTY'S DRAWING No.	AS PER DRAWING
ALLOY & TEMPER	HE9 WP
DESCRIPTION	MOTOR BODY