

P-9211-3
S2195
27256

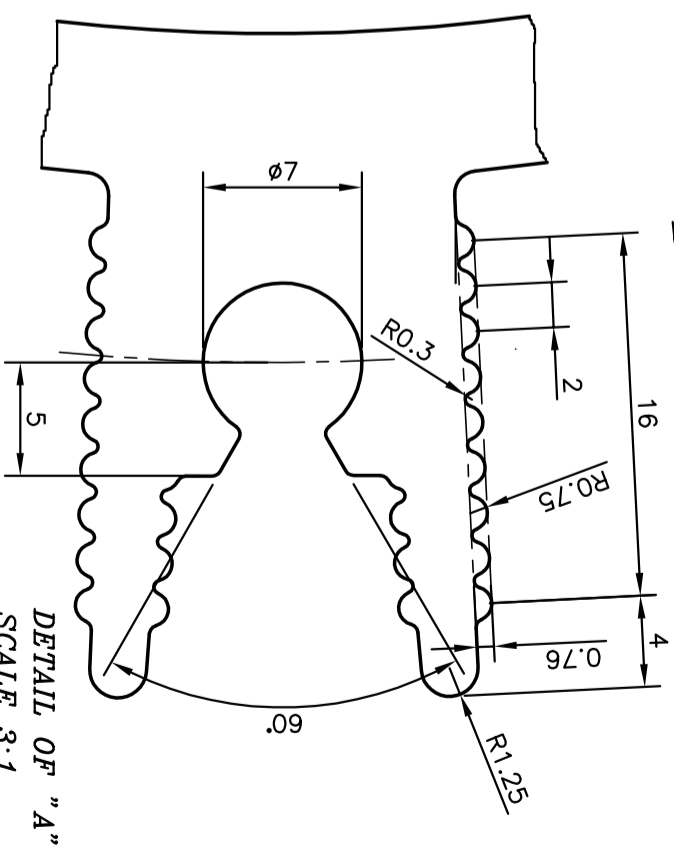
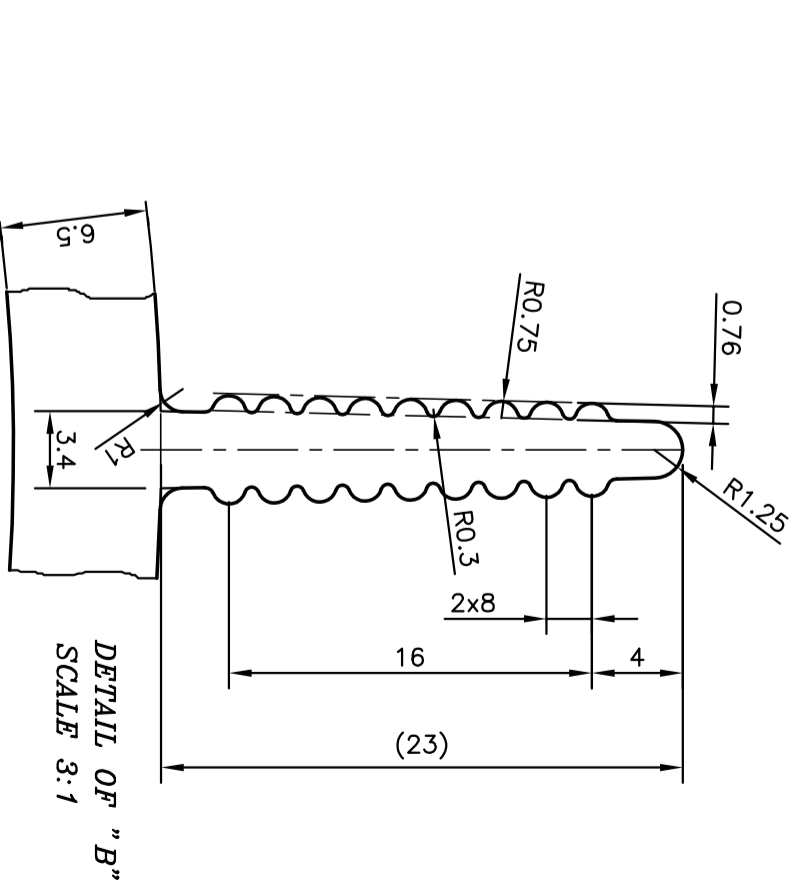
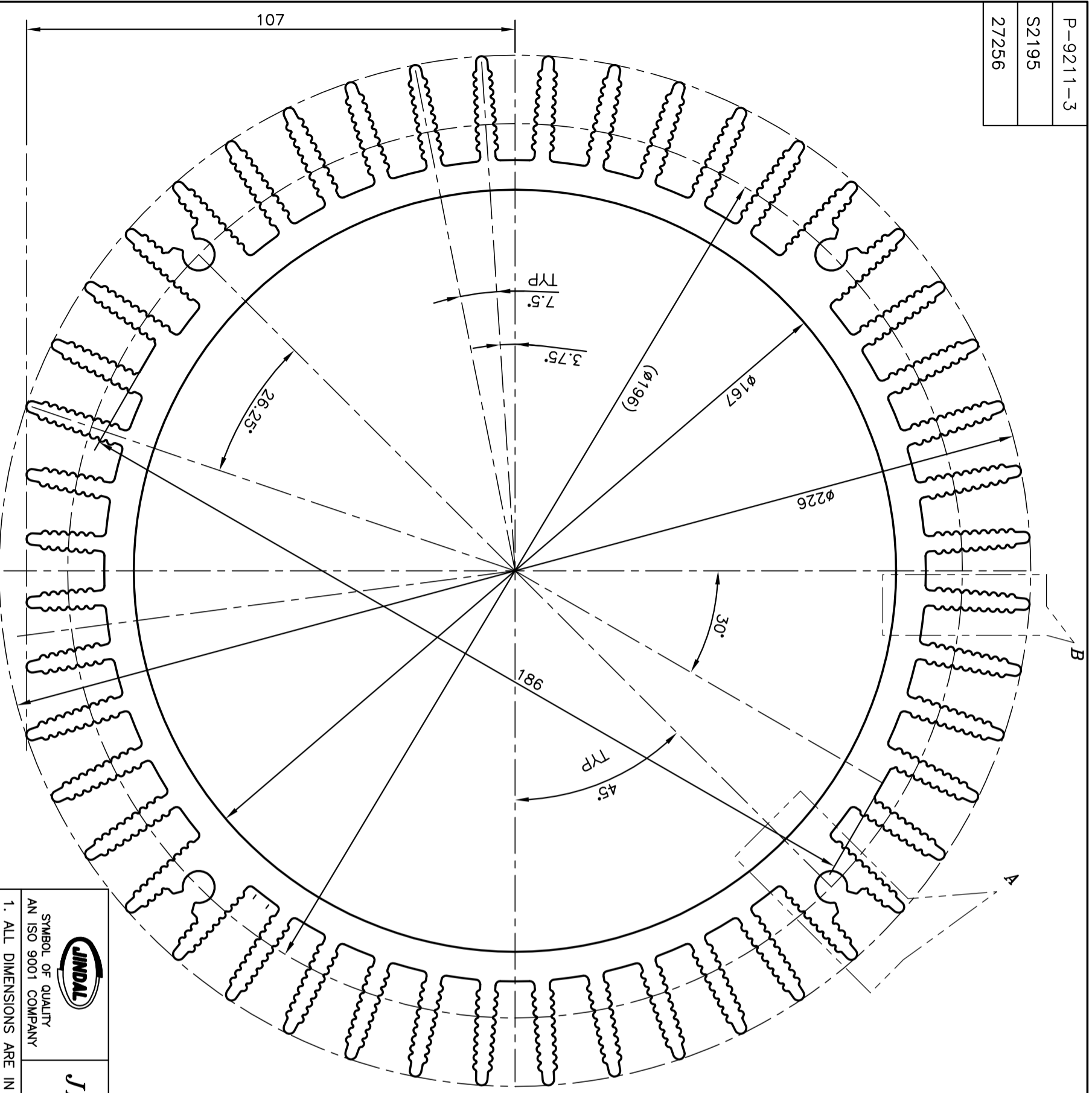

JINDAL
SYMBOL OF QUALITY
AN ISO 9001 COMPANY

JINDAL ALUMINIUM LTD.
BANGALORE-560073 (INDIA)

1. ALL DIMENSIONS ARE IN mm.
2. ROUND OFF ALL SHARP CORNERS WITH 0.40 mm.
3. TOLERANCES WILL BE AS PER IS:6477-1983 UNLESS OTHERWISE SPECIFIED

PARTY'S NAME
PARTY'S DRAWING No.
ALLOY & TEMPER
DESCRIPTION

REVA ELECTRIC CAR CO. (P) LTD., BANGALORE	921-02-12	HE9 WP	STATOR FRAME SECTION
NAME	DATE		
DRAWN J.P. KAUSHIK	20-06-2009		
CHECKED			
APPROVED			
SCALE	1:1		
AREA mm ²	7787.29		
PERIMETER mm.	3077.111		
WEIGHT kg/m	21.026		
DRAWING No.	SECTION No.		
P-9211-3	-		
S2195	S2195		
27256	27256		