

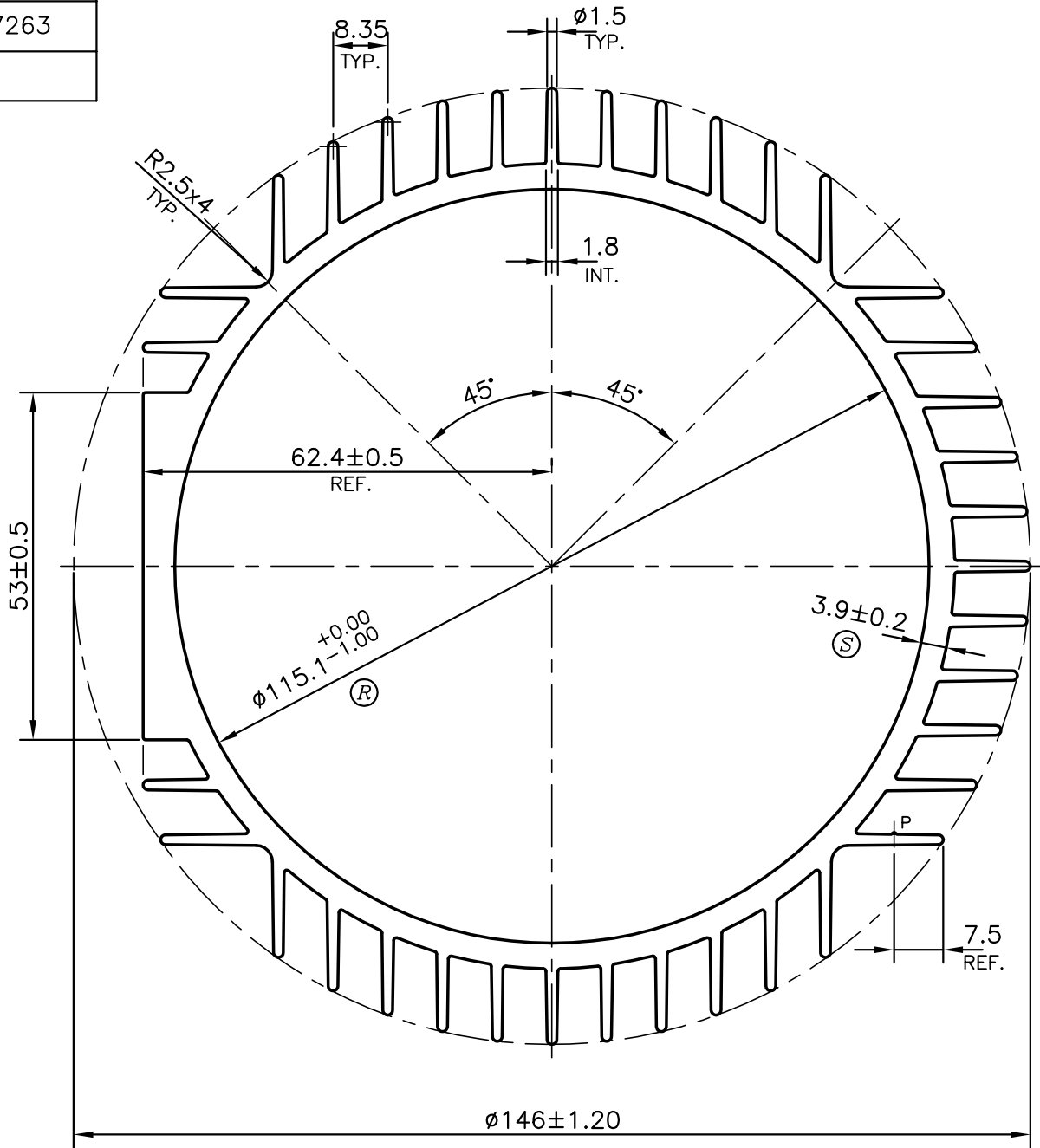

P-12516-1

27263



NOTE:-
R & S CRITICAL DIMENSIONS

P = PIP 0.3x90° (1 PLACE)

 SYMBOL OF QUALITY AN ISO 9001 COMPANY	JINDAL ALUMINIUM LTD. BANGALORE-560073 (INDIA)	DRAWN	NAME	DATE
		CHECKED	PARVESH	16-02-2013
1. ALL DIMENSIONS ARE IN mm. 2. ROUND OFF ALL SHARP CORNERS WITH 0.40 mm. 3. TOLERANCES WILL BE AS PER IS:6477-1983, UNLESS OTHERWISE SPECIFIED		APPROVED	S.S.GARG	21-02-2013
		SCALE		1:1
PARTY'S NAME GENERAL CATEGORY, COIMBATORE MARKET		AREA	mm ²	2376.388
		PERIMETER	mm.	1271.298
PARTY'S DRAWING No. AS PER DRAWING		WEIGHT	kg/m	6.416
		DRAWING No.	SECTION No.	
ALLOY & TEMPER HE9 WP		P-12516-1		
		27263	27263	
DESCRIPTION PUMP BODY SECTION				