

P-12517-1

27264

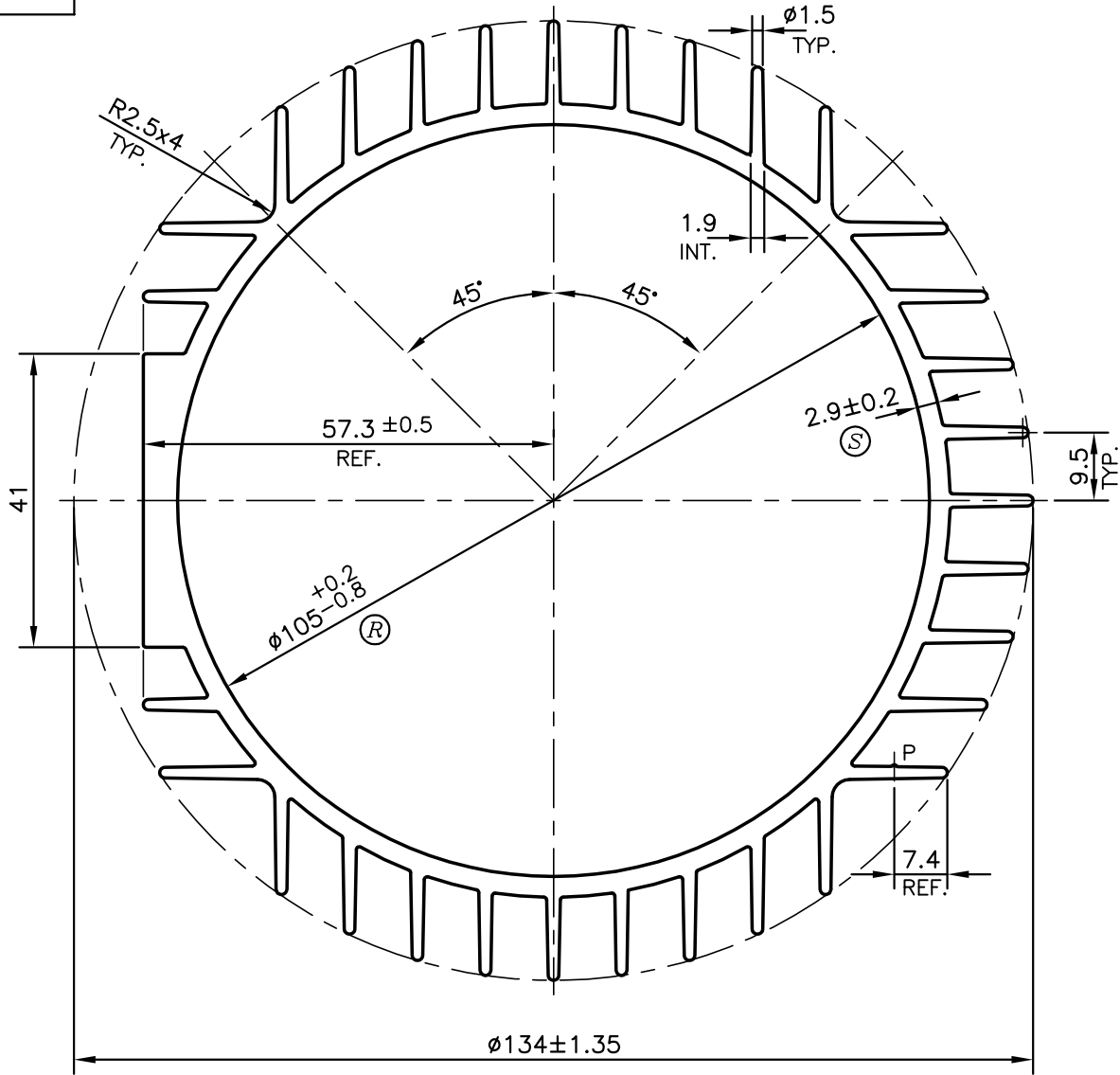

**NOTE:-**  
R & S CRITICAL DIMENSIONS

**ISSUE (2) :-**  
DRAWING REVISED  
AND WEIGHT ALSO CHANGED FROM  
4.663 kg/m TO 4.805 kg/m.

P = PIP 0.3x90° (1 PLACE)

 SYMBOL OF QUALITY AN ISO 9001 COMPANY	<b>JINDAL ALUMINIUM LTD.</b> BANGALORE-560073 (INDIA)	NAME	DATE
		DRAWN	PARVESH 30-04-2013
		CHECKED	
		APPROVED	S.S.GARG 03-05-2013
		SCALE	1:1
		AREA mm <sup>2</sup>	1779.457
		PERIMETER mm.	1086.166
		WEIGHT kg/m	4.805
PARTY'S NAME	GENERAL CATEGORY, COIMBATORE MARKET	DRAWING No.	SECTION No.
PARTY'S DRAWING No.	AS PER DRAWING	P-12517-1	
ALLOY & TEMPER	HE9 WP	27264	27264 (ISSUE-2)
DESCRIPTION	PUMP BODY SECTION		