

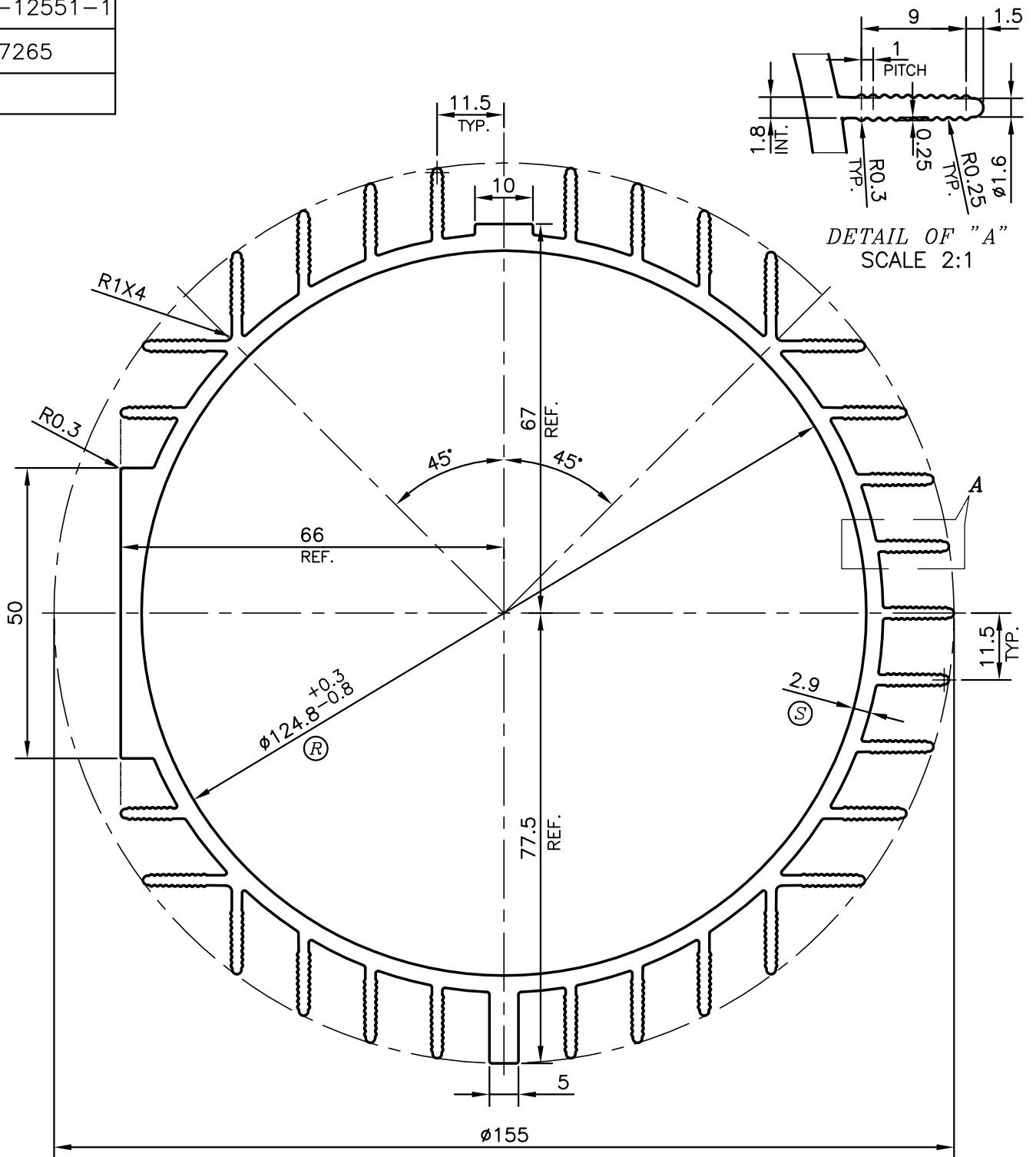

P-12551-1

27265



DETAIL OF "A"
SCALE 2:1

NOTE:-
R & S CRITICAL DIMENSIONS

 SYMBOL OF QUALITY AN ISO 9001 COMPANY	JINDAL ALUMINIUM LTD. BANGALORE-560073 (INDIA)	NAME	DATE
		DRAWN	PARVESH 20-02-2013
		CHECKED	
		APPROVED	S.S.CARG 26-08-2012
1. ALL DIMENSIONS ARE IN mm. 2. ROUND OFF ALL SHARP CORNERS WITH 0.40 mm. 3. TOLERANCES WILL BE AS PER IS:6477-1983, UNLESS OTHERWISE SPECIFIED		SCALE	1:1
		AREA mm ²	2095.498
		PERIMETER mm.	1271.762
PARTY'S NAME	GENERAL CATEGORY, COIMBATORE MARKET	WEIGHT kg/m	5.658
PARTY'S DRAWING No.	AS PER REQUIRMENT	DRAWING No.	SECTION No.
ALLOY & TEMPER	HE9 WP	P-12551-1	-
DESCRIPTION	PUMP BODY	27265	27265