

P-16809-1

27280

THESE TWO FINS HIGHT REDUCED

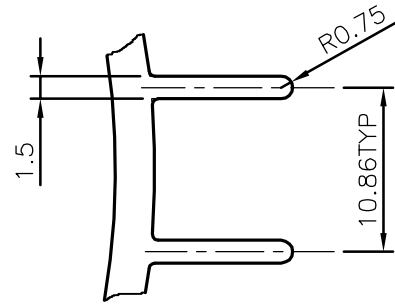

DETAIL "A"
SCALE 2:1

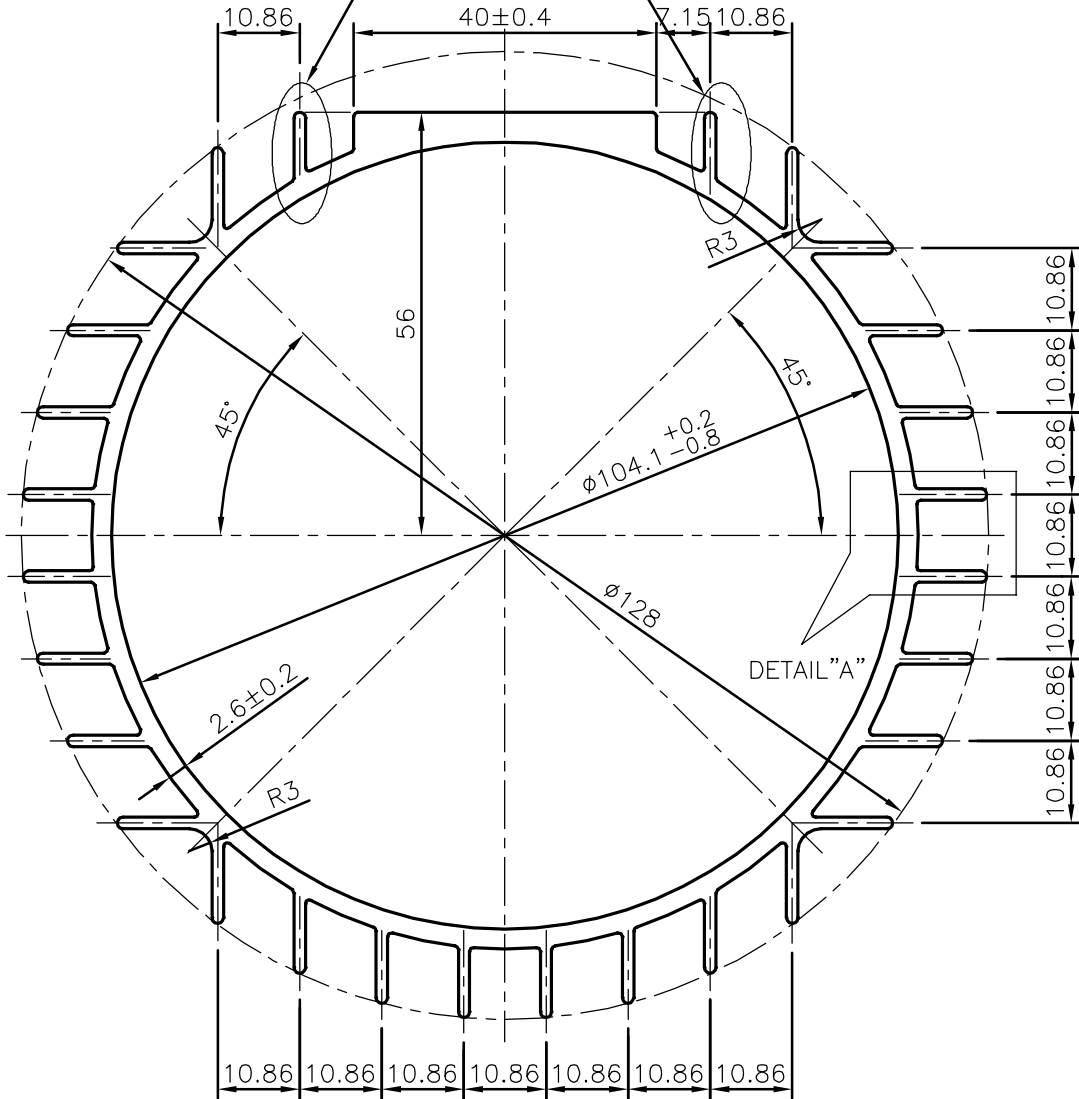

SYMBOL OF QUALITY
AN ISO 9002 COMPANY

JINDAL ALUMINIUM LTD.
BANGALORE-560073 (INDIA)

	NAME	DATE
DRAWN	J.P.KAUSHIK	25-02-2017
CHECKED		
APPROVED	B.NATARAJ	07-03-2017

1. ALL DIMENSIONS ARE IN mm.
2. ROUND OFF ALL SHARP CORNERS WITH 0.50 mm.
3. TOLERANCES WILL BE AS PER IS:6477-1983 UNLESS OTHERWISE SPECIFIED

SCALE	1:1
AREA mm ²	1417.372
PERIMETER mm.	883.365
WEIGHT kg/m	3.827

PARTY'S NAME	GENERAL CATEGORY, COIMBATORE MARKET	DRAWING No.	SECTION No.
PARTY'S DRAWING No.	MODIFIED OF 27236 & REQUIREMENT	P-16809-1	-
ALLOY & TEMPER	HE9 WP	27280	27280
DESCRIPTION	MOTOR BODY SECTION		