

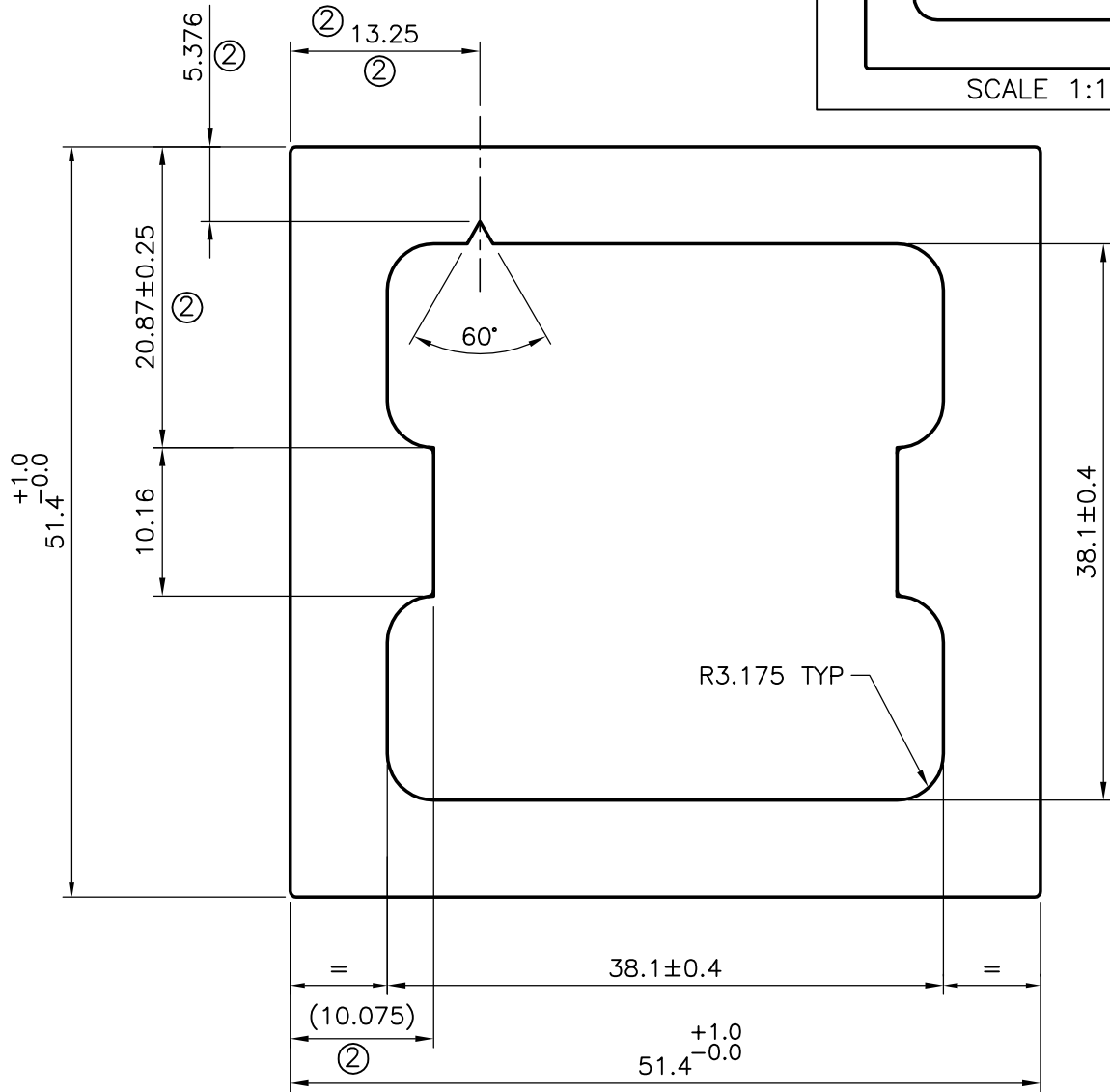

S695
7056
27352

NOTE:-

1. FLATNESS = $\pm 0.25\text{mm}$
2. ANGULARITY = $\pm 2^\circ$

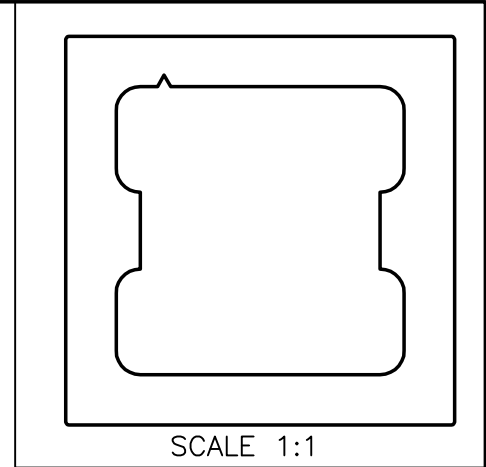

ISSUE-2:- TOLERANCE CHANGED FROM 51.4 ± 0.50 TO $51.4 \begin{smallmatrix} +1.0 \\ -0.0 \end{smallmatrix}$
 DIMENSIONS CHANGED FROM 13 TO 13.25, 20.62 TO 20.87, 9.825 TO 10.075 &
 FROM 5.126 TO 5.376

 SYMBOL OF QUALITY AN ISO 9001 COMPANY	JINDAL ALUMINIUM LTD. BANGALORE-560073 (INDIA)	DRAWN	J.P.KAUSHIK	DATE	09-07-2011
		CHECKED			
1. ALL DIMENSIONS ARE IN mm. 2. ROUND OFF ALL SHARP CORNERS WITH 0.40 mm. 3. TOLERANCES WILL BE AS PER, IS:6477-1983 UNLESS OTHERWISE SPECIFIED		APPROVED	S.S.GARG		16-07-2011
		SCALE			2:1
PARTY'S NAME MARVEL MACHINE TOOL., THIRUVALLUR		AREA mm ²			1270.694
		PERIMETER mm.			204.913
PARTY'S DRAWING No. AS PER DRAWING (B12-0130L-REV J)		WEIGHT kg/m			3.431
		DRAWING No.	S695	SECTION No.	S695
ALLOY & TEMPER HE9 WP			7056		7056
			27352		27352(ISSUE-2)
DESCRIPTION MISC TUBE					