

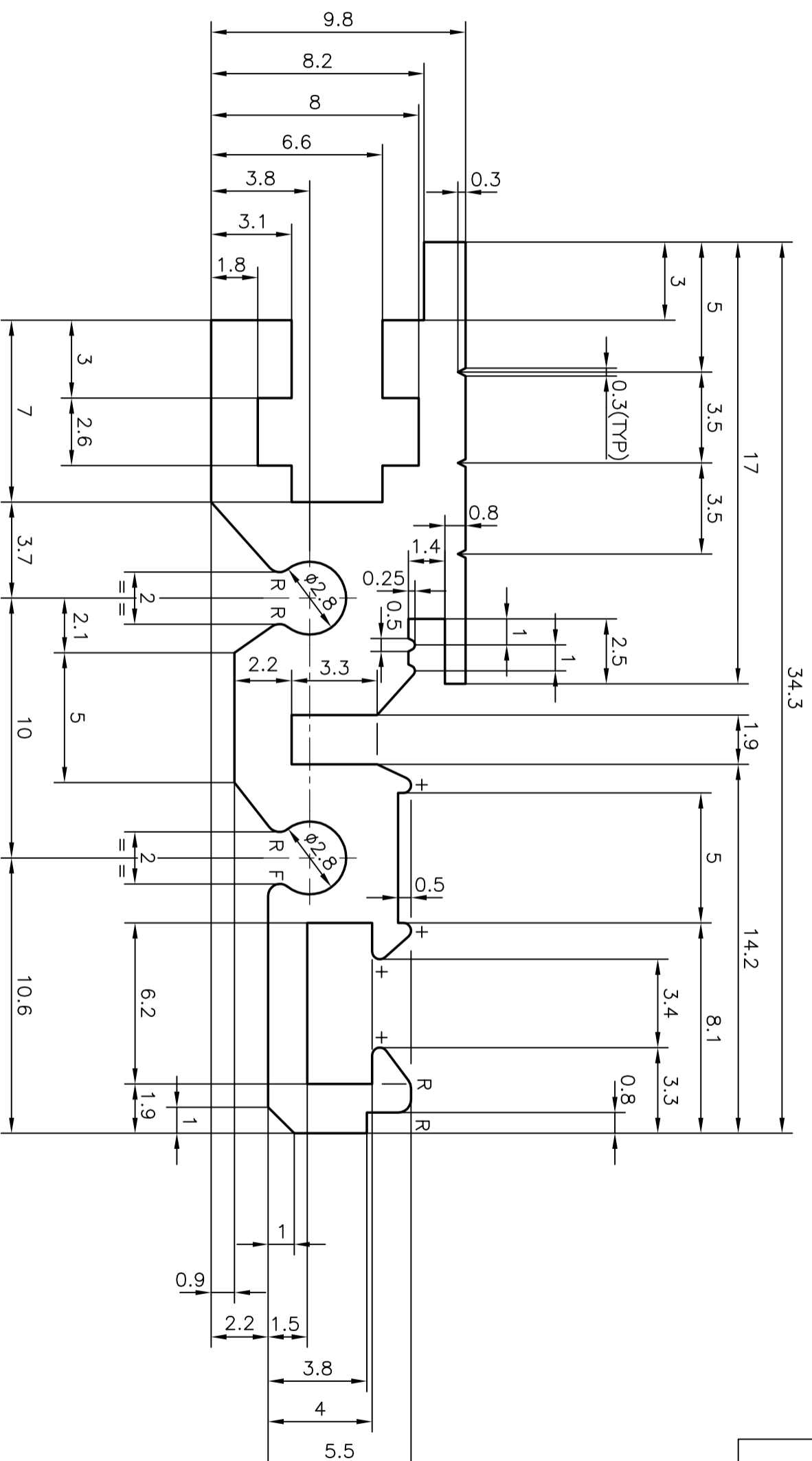

1:1



R = 0.5 RADIUS (5)  
 F = FULL RADIUS (1)  
 + = 0.3 RADIUS (4)

<b>JINDAL ALUMINIUM LTD.</b> BANGALORE - 560073		NAME	DATE
1. ALL DIMENSIONS ARE IN mm. 2. ROUND OFF ALL SHARP CORNERS WITH 0.4 mm. 3. TOLERANCES WILL BE AS PER IS: 3965-1981, UNLESS OTHERWISE SPECIFIED		DRAWN	R.D.Sharma
10-03-97		CHECKED	
PARTY'S NAME MRO-TEK PRIVATE LTD., BANGALORE		APPROVED	
PARTY'S DRAWING No. 109		SCALE	1:1 & 5:1
ALLOY & TEMPER HE9 WP (63400 WP)		WEIGHT kg/m	0.398
LENGTH 1750 mm.		SECTION No.	27414
DESCRIPTION RACK EXTRUSION		DRAWING No.	27414