

S673
9286
27533

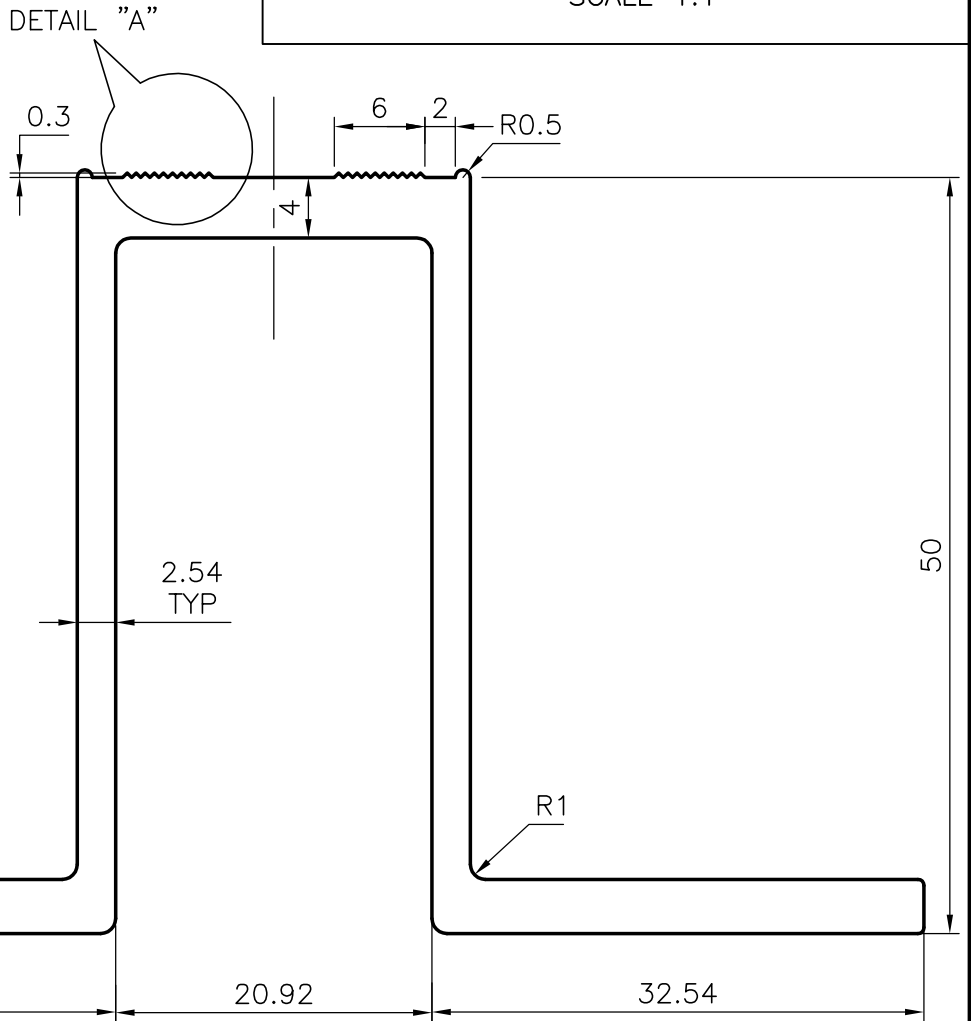
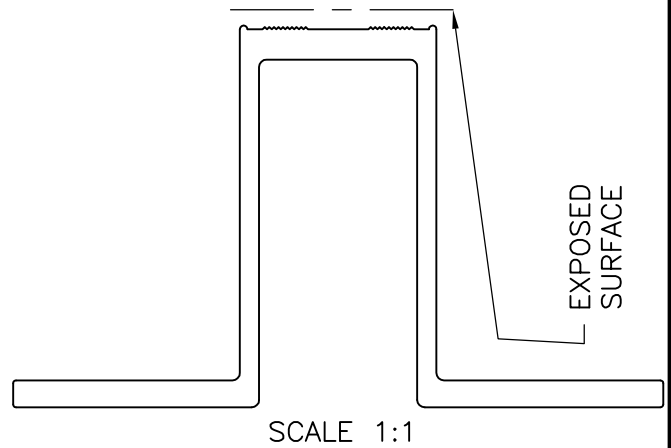
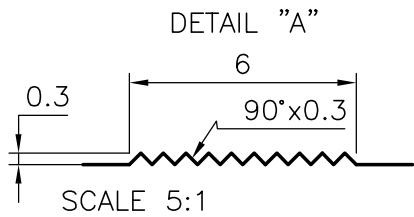

JINDAL ALUMINIUM LTD.
BANGALORE-560073 (INDIA)

	NAME	DATE
DRAWN	RAGHAVENDRA	18-04-01
CHECKED		
APPROVED		

1. ALL DIMENSIONS ARE IN mm.
2. ROUND OFF ALL SHARP CORNERS WITH 0.40 mm.
3. TOLERANCES WILL BE AS PER IS 3965-1981 UNLESS OTHERWISE SPECIFIED

PARTY'S NAME	TANK TECH ASIA PVT LTD , CHENNAI
PARTY'S DRAWING No.	AS PER DRAWING (EXT-006-R1)
ALLOY & TEMPER	6005-T5
DESCRIPTION	SPACER EXTRUSION

SCALE	2:1 & 1:1
WEIGHT kg/m	1.499
SECTION No.	27533
DRAWING No.	27533