

P-4912-2

27551

TWIST = 1°/300mm MAXIMUM OVER THE FULL LENGTH 5°
 STRAIGHTNESS = 1.5mm/M
 F = FULL RADIUS (4 PLACES)
 ALL EXTERNAL SURFACES ARE VISIBLE & BETTER
 FINISH REQUIRED

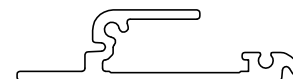

SCALE 1:1

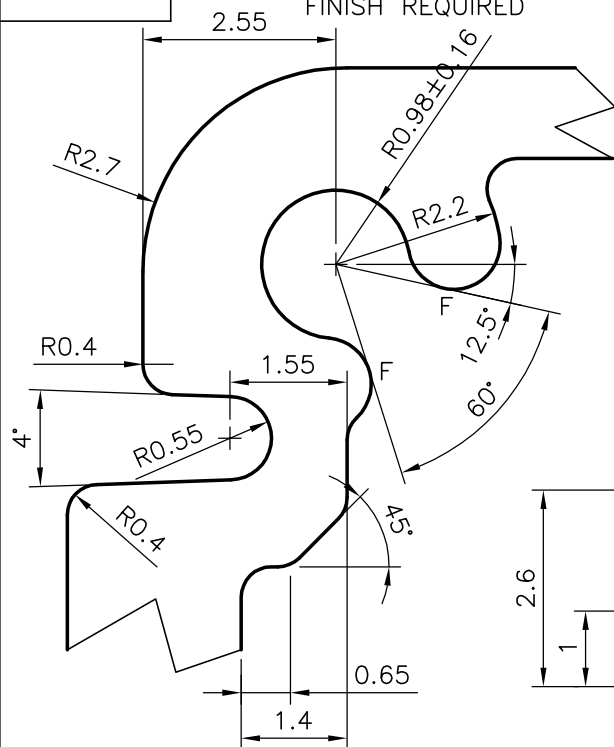

DETAIL "B"
SCALE 10:1

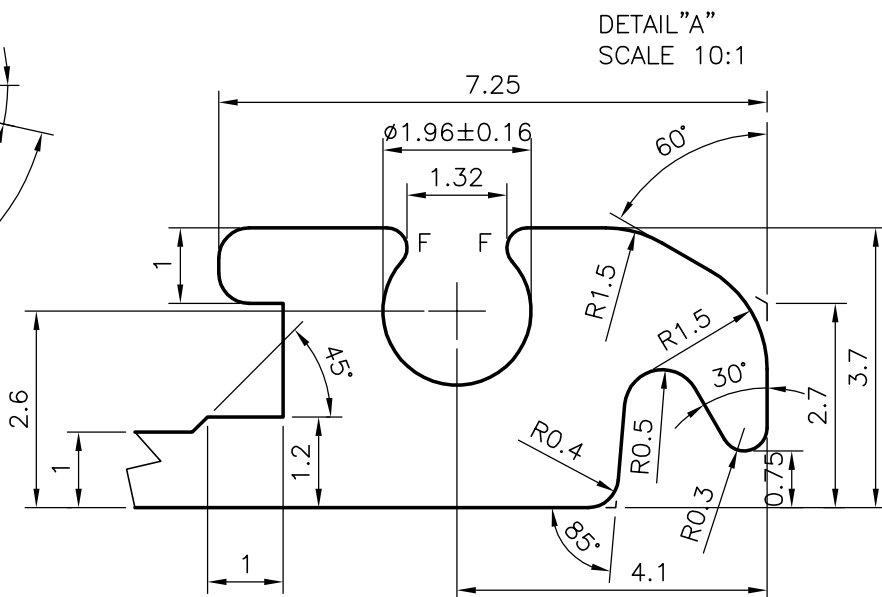

DETAIL "A"
SCALE 10:1

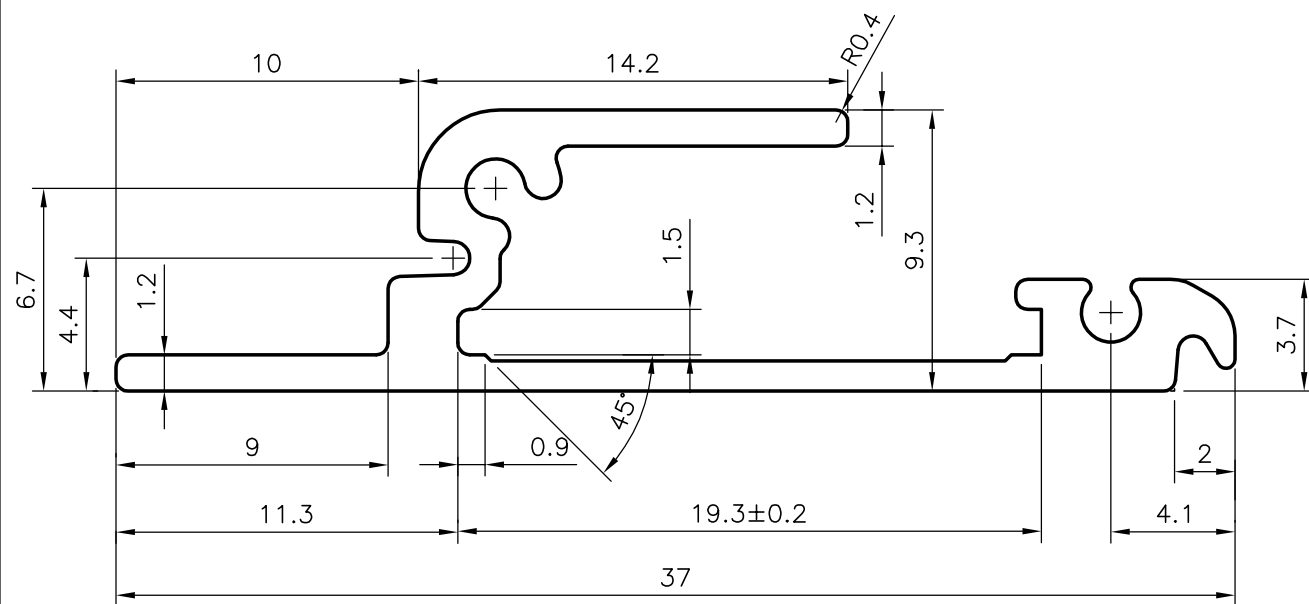

JINDAL ALUMINIUM LTD.
 BANGALORE-560073 (INDIA)

	NAME	DATE
DRAWN	RAGHAVENDRA	11-08-2004
CHECKED		
APPROVED		

1. ALL DIMENSIONS ARE IN mm.
2. ROUND OFF ALL SHARP CORNERS WITH 0.40 mm.
3. TOLERANCES WILL BE AS PER BS:1474-1987 UNLESS OTHERWISE SPECIFIED

SCALE	4:1
AREA mm ²	84.02
PERIMETER mm.	131.881
WEIGHT kg/m	0.227

PARTY'S NAME	TL JONES LTD, CHRISTCHURCH NEW ZEALAND
PARTY'S DRAWING No.	EDS2186
ALLOY & TEMPER	6063 T5
DESCRIPTION	DSL EXTRUSION PROFILE-ELEVATOR

DRAWING No.	SECTION No.
P-4912-2	-
27551	27551