

P-4056-1

S982

27580

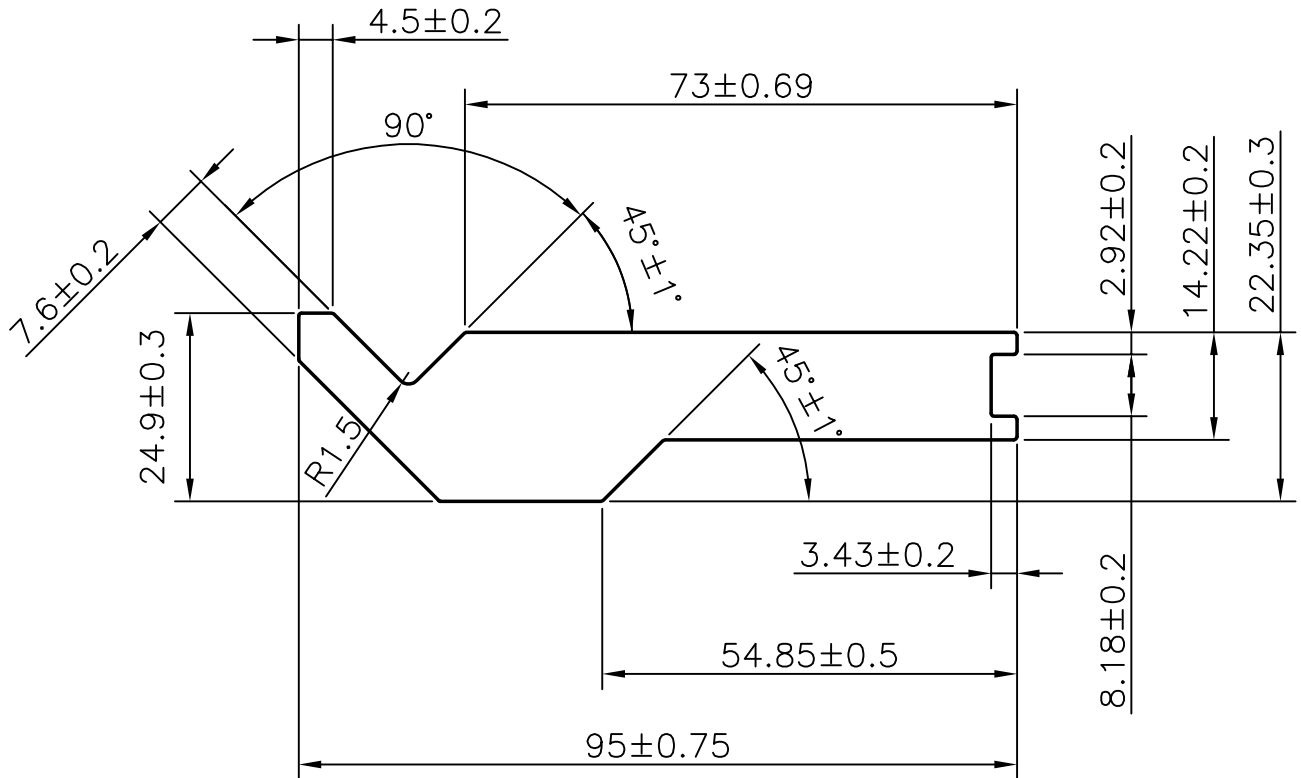

EXTRUSIONS SHOULD BE FREE FROM SCRATCHES, DENTS ETC.



SYMBOL OF QUALITY
AN ISO 9002 COMPANY

JINDAL ALUMINIUM LTD.
BANGALORE-560073 (INDIA)

	NAME	DATE
DRAWN	R.D.Sharma	07-02-03
CHECKED		
APPROVED		

1. ALL DIMENSIONS ARE IN mm.
2. ROUND OFF ALL SHARP CORNERS WITH 0.40 mm.
3. TOLERANCES WILL BE AS PER IS: 3965-1981 UNLESS OTHERWISE SPECIFIED

SCALE	1:1
AREA mm ²	1467.6
PERIMETER mm.	233.7
WEIGHT kg/m	3.962
SECTION No.	27580
DRAWING No.	27580

PARTY'S NAME	EASTERN ENGINEERING CO., BANGALORE
PARTY'S DRAWING No.	243364-PI & AS PER SAMPLE
ALLOY & TEMPER	6351 T6
DESCRIPTION	FLIPPER