

P-4191

S991

27582

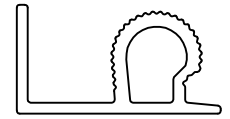

1:1

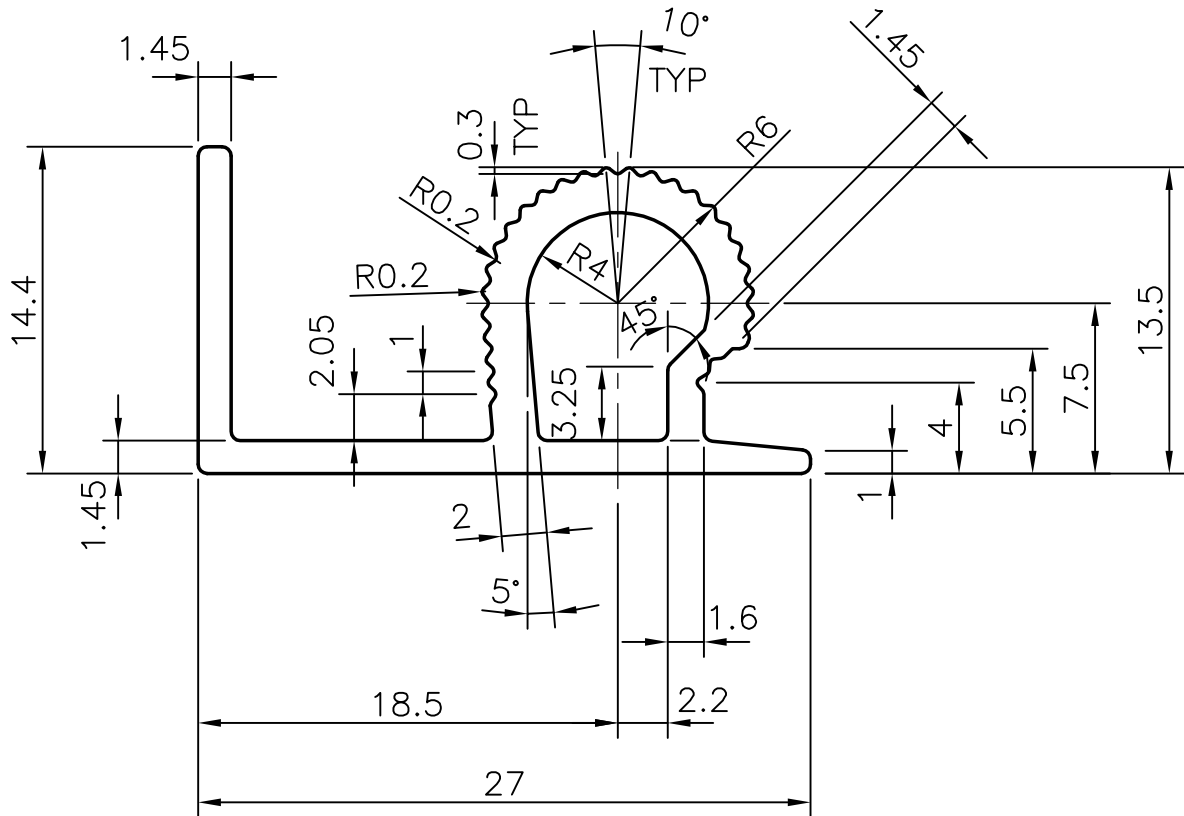

SYMBOL OF QUALITY  
AN ISO 9002 COMPANY

**JINDAL ALUMINIUM LTD.**  
BANGALORE-560073 (INDIA)

	NAME	DATE
DRAWN	R.D.Sharma	16-04-03
CHECKED		
APPROVED		

1. ALL DIMENSIONS ARE IN mm.
2. ROUND OFF ALL SHARP CORNERS WITH 0.40 mm.
3. TOLERANCES WILL BE AS PER IS: 6477-1983 UNLESS OTHERWISE SPECIFIED

SCALE	3:1
AREA mm <sup>2</sup>	107.7
PERIMETER mm.	108.3
WEIGHT kg/m	0.291
SECTION No.	27582
DRAWING No.	27582

PARTY'S NAME	SRI SUBRAMANYA ENTERPRISES, BANGALORE
PARTY'S DRAWING No.	AS PER SAMPLE
ALLOY & TEMPER	HE9 WP
DESCRIPTION	MISCELLANEOUS SECTION