

P-5118  
S1342  
27585

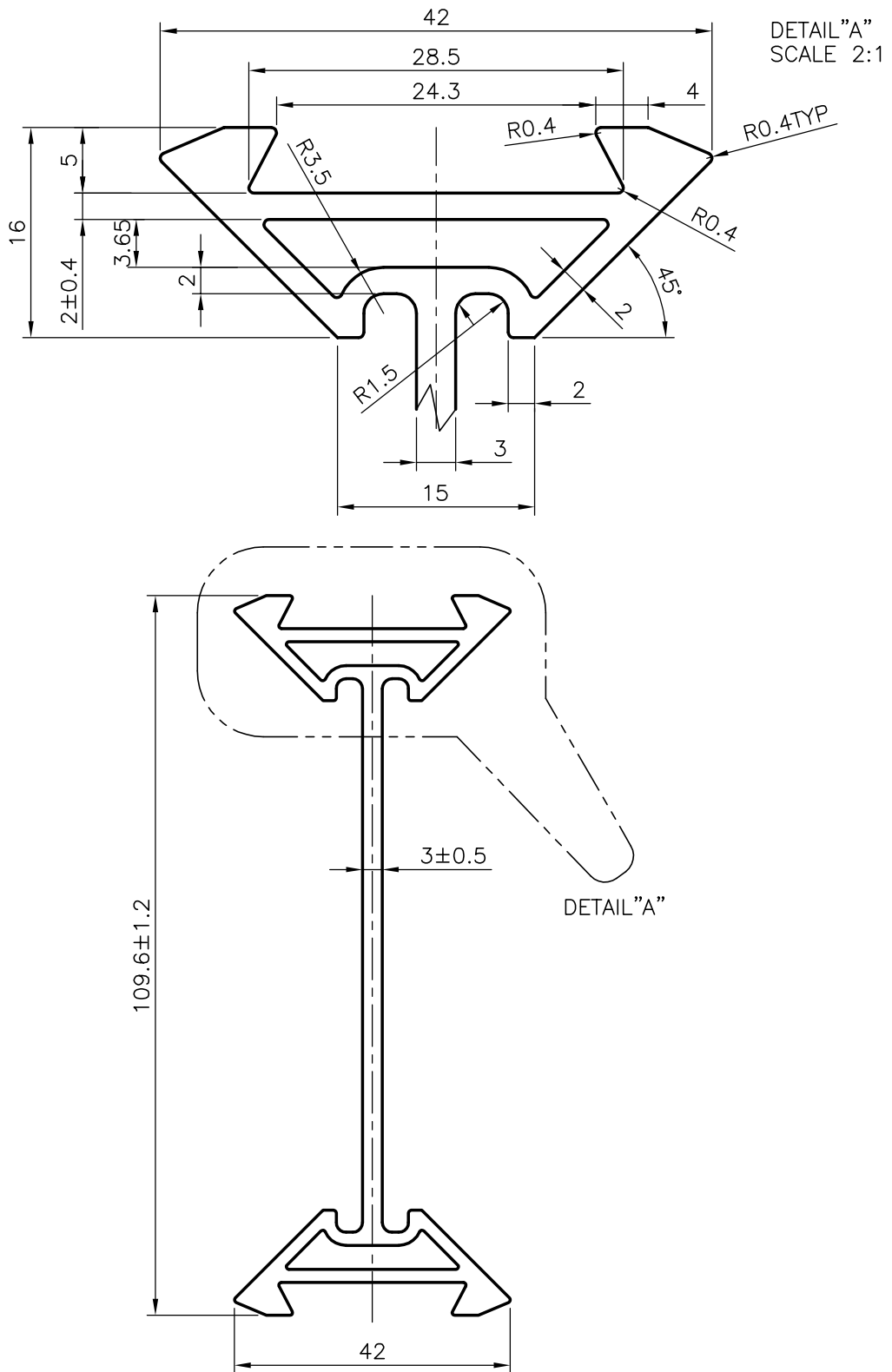

**JINDAL ALUMINIUM LTD.**  
BANGALORE-560073 (INDIA)

	NAME	DATE
DRAWN	RAGHAVENDRA	21-10-2004
CHECKED		
APPROVED		

1. ALL DIMENSIONS ARE IN mm.
2. ROUND OFF ALL SHARP CORNERS WITH 0.40 mm.
3. TOLERANCES WILL BE AS PER IS:6477-1983 UNLESS OTHERWISE SPECIFIED

SCALE	1:1
AREA mm <sup>2</sup>	683.379
PERIMETER mm.	392.694
WEIGHT kg/m	1.845

PARTY'S NAME	RAMSONS GARMENT FINISHING EQUIPMENT PVT LTD, BANGALORE
PARTY'S DRAWING No.	AS PER SAMPLE
ALLOY & TEMPER	HE9 WP
DESCRIPTION	INDUSTRIAL MISC. SECTION

DRAWING No.	SECTION No.
P-5118	-
S1342	S1342
27585	27585