

P-5169-1

S1395

27672

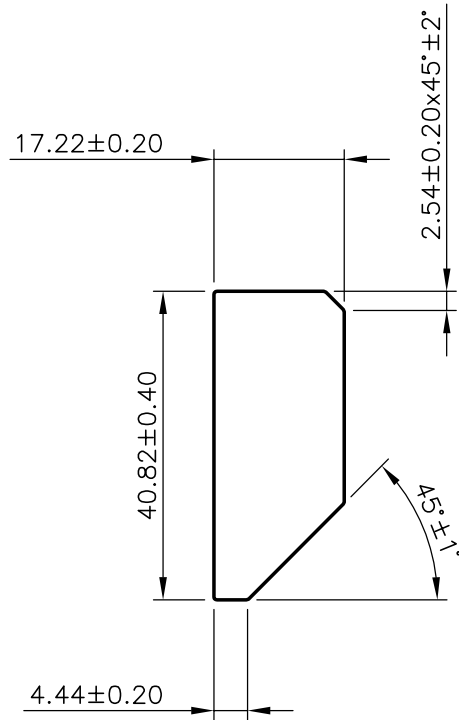

1. STRAIGHTNESS:- 1.70 mm./M
2. TWIST:- 1.70 mm./M
3. FLATNESS:- 0.50 mm.



SYMBOL OF QUALITY  
AN ISO 9001 COMPANY

**JINDAL ALUMINIUM LTD.**  
BANGALORE-560073 (INDIA)

	NAME	DATE
DRAWN	RAGHAVENDRA	14-12-2004
CHECKED		
APPROVED		
SCALE		1:1
AREA mm <sup>2</sup>		617.95
PERIMETER mm.		106.69
WEIGHT kg/m		1.668
DRAWING No.		SECTION No.
P-5169-1		-
S1395		S1395
27672		27672

1. ALL DIMENSIONS ARE IN mm.
2. ROUND OFF ALL SHARP CORNERS WITH 0.40 mm.
3. TOLERANCES WILL BE AS PER IS:3965-1981 UNLESS OTHERWISE SPECIFIED

PARTY'S NAME	SPRAYING SYSTEMS (INDIA) PVT. LTD. BANGALORE
PARTY'S DRAWING No.	R57134
ALLOY & TEMPER	6351 T6
DESCRIPTION	MISCELLANEOUS BAR