

P-5170-1

S1399

27682

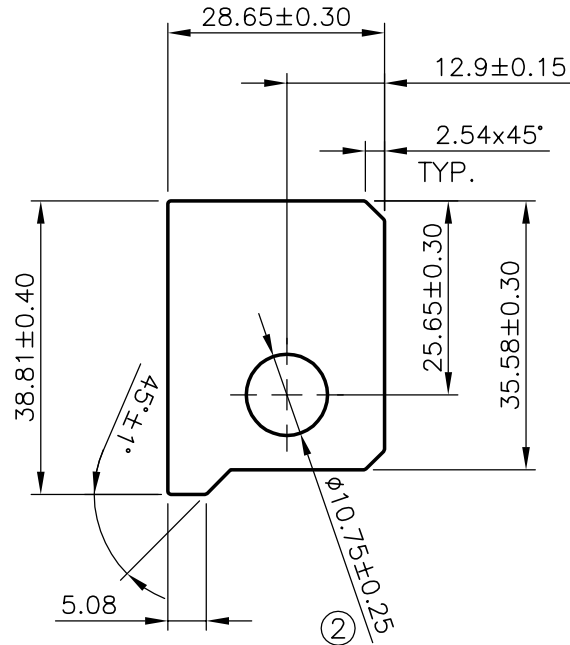

1. STRAIGHTNESS:- 1.70 mm./M
2. TWIST:- 1.70 mm./M
3. FLATNESS:- 0.50 mm.

ISSUE-2 DIMENSION CHANGED FROM $\phi 10.85 \pm 0.15$ TO $\phi 10.75 \pm 0.25$

 SYMBOL OF QUALITY AN ISO 9001 COMPANY	JINDAL ALUMINIUM LTD. <i>BANGALORE-560073 (INDIA)</i>	DRAWN	NAME	DATE
		CHECKED	MALINGAPPA	02.03.2005
1. ALL DIMENSIONS ARE IN mm. 2. ROUND OFF ALL SHARP CORNERS WITH 0.40 mm. 3. TOLERANCES WILL BE AS PER IS:6477-1983 UNLESS OTHERWISE SPECIFIED		APPROVED		
		SCALE		1:1
PARTY'S NAME SPRAYING SYSTEMS (INDIA) PVT. LTD. BANGALORE		AREA	mm ²	943.692
		PERIMETER	mm.	129.622
PARTY'S DRAWING No. R57133		WEIGHT	kg/m	2.548
		DRAWING No.		SECTION No.
ALLOY & TEMPER 6351 T6		P-5170-1		-
		S1399		S1399 ISSUE-2
DESCRIPTION MISCELLANEOUS SECTION		27682		27682