

P-8390-1

27780

DETAIL OF "A"
SCALE 3:1

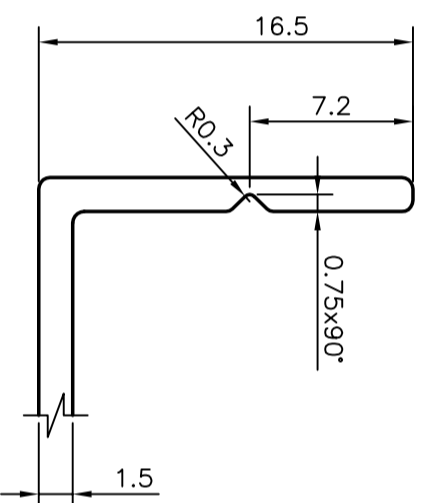

DETAIL OF "B"
SCALE 3:1

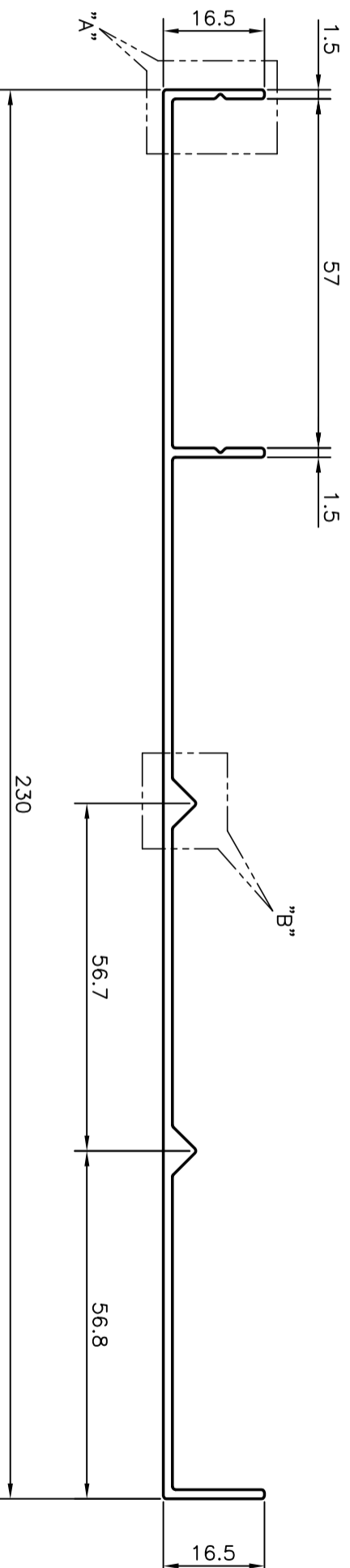
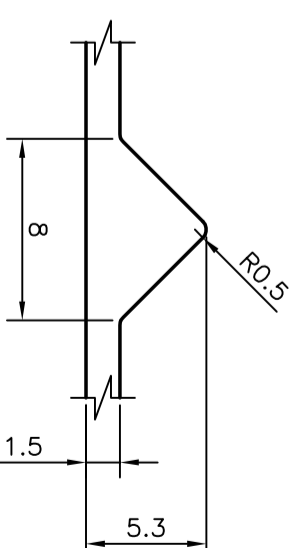

 <p>SYMBOL OF QUALITY AN ISO 9001 COMPANY</p>	<p>JINDAL ALUMINIUM LTD. BANGALORE-560073 (INDIA)</p>		NAME	PRASANNAH	DATE	26-06-2008
	<p>1. ALL DIMENSIONS ARE IN mm. 2. ROUND OFF ALL SHARP CORNERS WITH 0.40 mm. 3. TOLERANCES WILL BE AS PER IS:3965-1981 UNLESS OTHERWISE SPECIFIED</p>		CHECKED			
PARTY'S NAME	CHINNIWALAS PVT. LTD., PUNE	SCALE	1:1	APPROVED		
PARTY'S DRAWING No.	AS PER DRAWING	AREA mm ²	442.758			
ALLOY & TEMPER	HE9 WP	PERIMETER mm.	557.679			
DESCRIPTION	COVER PLATE FOR WINDOW BOTTOM	WEIGHT kg/m	1.195			
		DRAWING No.	P-8390-1			
		SECTION No.	-			
			27780			
			27780			