

P-8578

27812

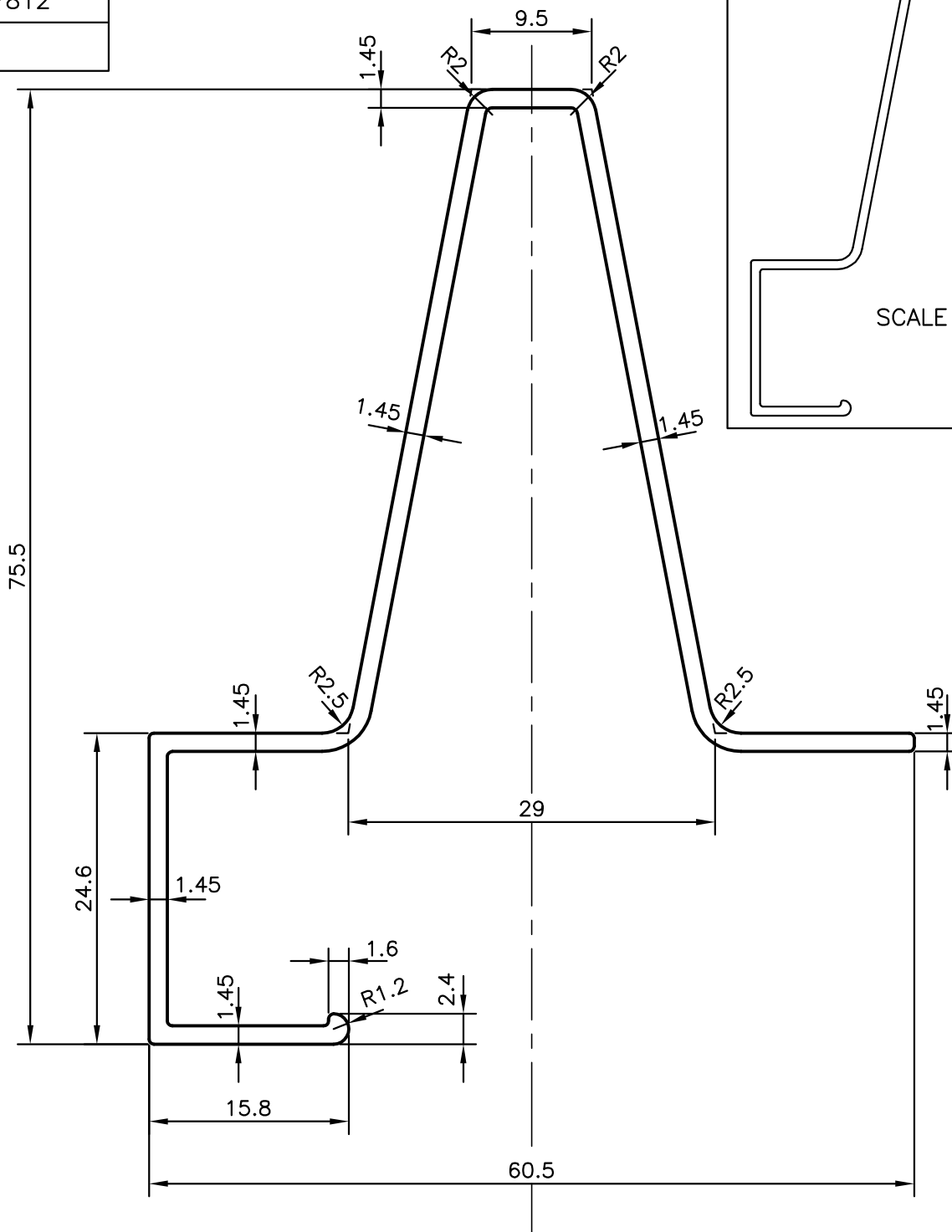

SCALE 1:1



SYMBOL OF QUALITY
AN ISO 9001 COMPANY

JINDAL ALUMINIUM LTD.
BANGALORE-560073 (INDIA)

	NAME	DATE
DRAWN	ABHARANI	25-08-2008
CHECKED		
APPROVED		
SCALE		2:1
AREA mm ²		261.406
PERIMETER mm.		361.81
WEIGHT kg/m		0.706
DRAWING No.	SECTION No.	
P-8578	-	
27812	27812	

1. ALL DIMENSIONS ARE IN mm.
2. ROUND OFF ALL SHARP CORNERS WITH 0.40 mm.
3. TOLERANCES WILL BE AS PER BS:EN-755 UNLESS OTHERWISE SPECIFIED

PARTY'S NAME	PROSOURCE INDUSTRIAL SOLUTIONS, CANADA
PARTY'S DRAWING No.	AS PER SAMPLE
ALLOY & TEMPER	6063 T6
DESCRIPTION	MISC. SECTION PROFILE