

P-8954

27818

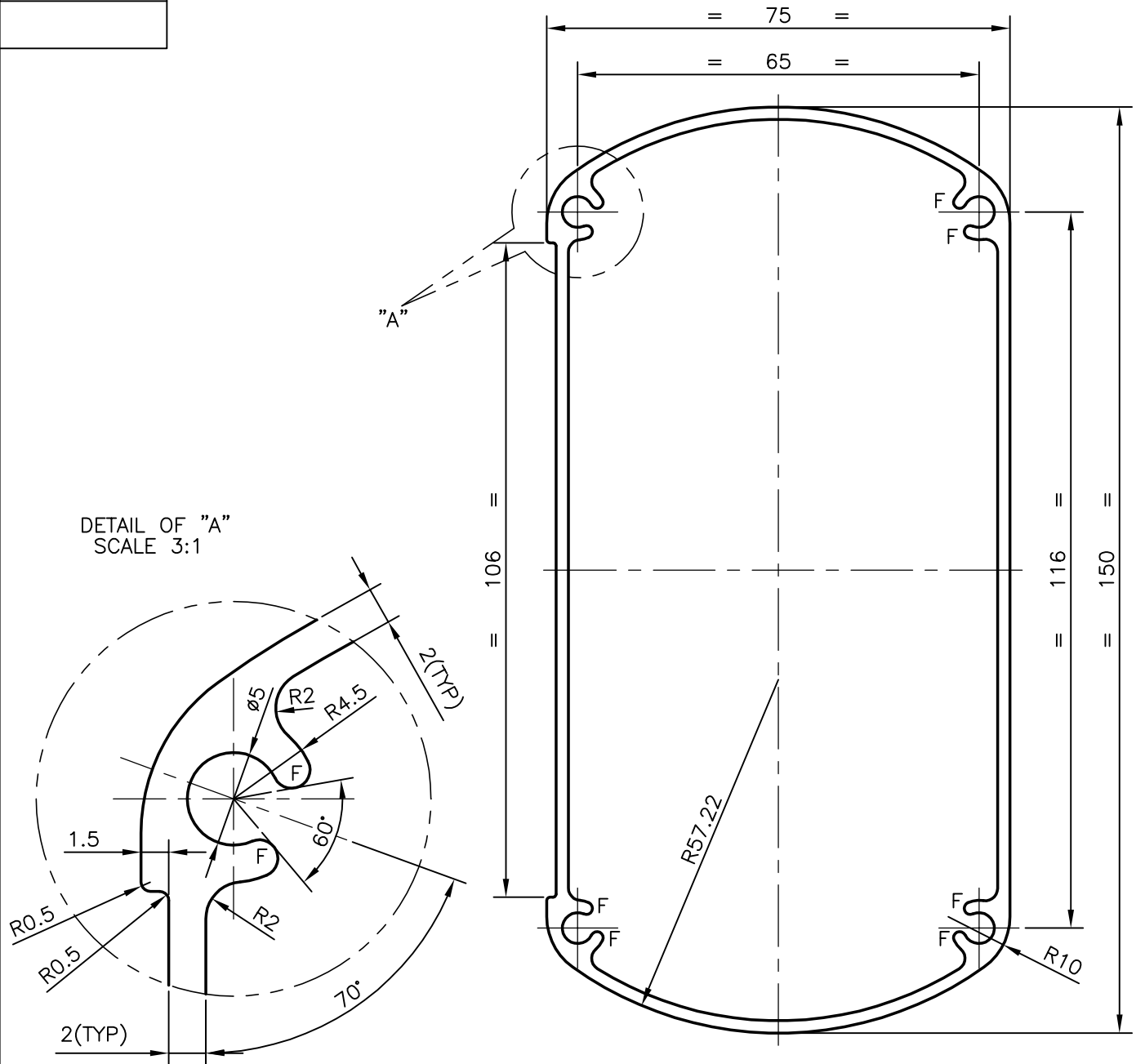

F = FULL RADIUS (8 PLACE)



SYMBOL OF QUALITY  
AN ISO 9001 COMPANY

**JINDAL ALUMINIUM LTD.**  
BANGALORE-560073 (INDIA)

	NAME	DATE
DRAWN	PRASANNA.H	29-12-2008
CHECKED		
APPROVED		

1. ALL DIMENSIONS ARE IN mm.
2. ROUND OFF ALL SHARP CORNERS WITH 0.40 mm.
3. TOLERANCES WILL BE AS PER IS:6477-1983 UNLESS OTHERWISE SPECIFIED

SCALE	1:1
AREA mm <sup>2</sup>	911.319
PERIMETER mm.	407.055
WEIGHT kg/m	2.461

PARTY'S NAME	NITIRAJ ENGINEERS PVT. LTD., PARWANOO
PARTY'S DRAWING No.	AS PER DRAWING
ALLOY & TEMPER	HE9 WP
DESCRIPTION	PBMI COLUMN SECTION

DRAWING No.	SECTION No.
P-8954	-
27818	27818