

P-6347-1
S1891
27831

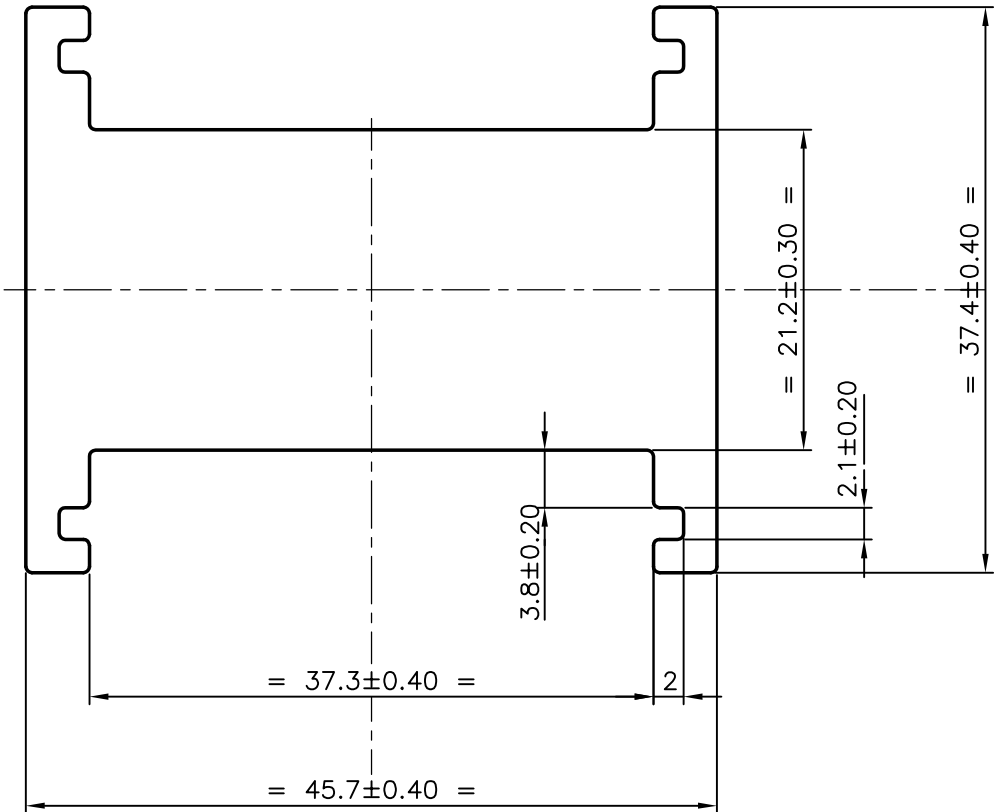
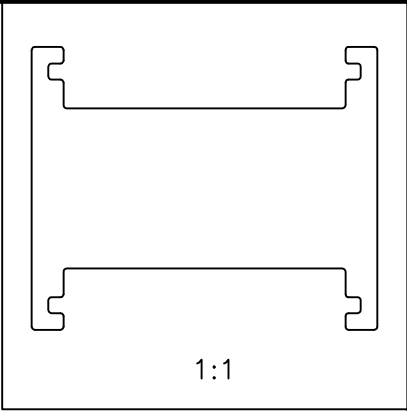

JINDAL ALUMINIUM LTD.
BANGALORE-560073 (INDIA)

	NAME	DATE
DRAWN	J.P.KAUSHIK	03-06-2006
CHECKED		
APPROVED		
SCALE	2:1	
AREA mm ²	1087.983	
PERIMETER mm.	209.793	
WEIGHT kg/m	2.938	
DRAWING No.	SECTION No.	
P-6347-1	-	
S1891	S1891	
27831	27831	

1. ALL DIMENSIONS ARE IN mm.
2. ROUND OFF ALL SHARP CORNERS WITH 0.4 mm.
3. TOLERANCES WILL BE AS PER IS:3965-1981 UNLESS OTHERWISE SPECIFIED

PARTY'S NAME	DYNAMIC GAUGES (P) LTD.,THANE
PARTY'S DRAWING No.	AS PER DRAWING
ALLOY & TEMPER	HE30 WP
DESCRIPTION	MISC.SECTION